

Providing Reliable Personal Protection in Electrical Installations with Frequency Converters

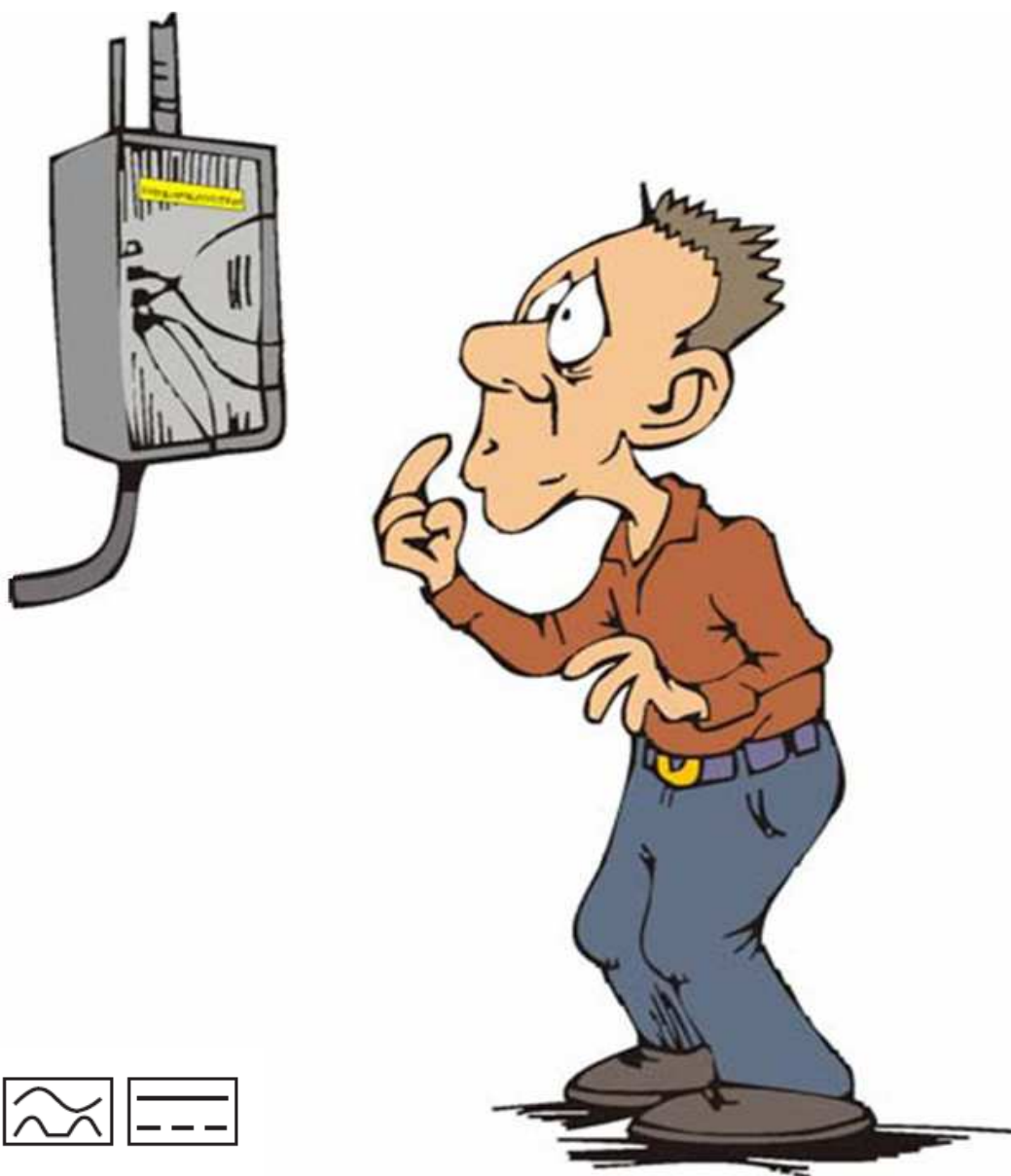

And why AC-DC sensitive?

1. Using AC-DC sensitive Residual Current Circuit-Breakers (Type B) in Electrical Installations with Frequency Converters:

Multi-phase operated electronic equipment such as frequency converters (FC) or current inverters can – in the event of a fault such as illustrated in Fig. 1 – generate smooth DC residual currents.

Fig. 1:

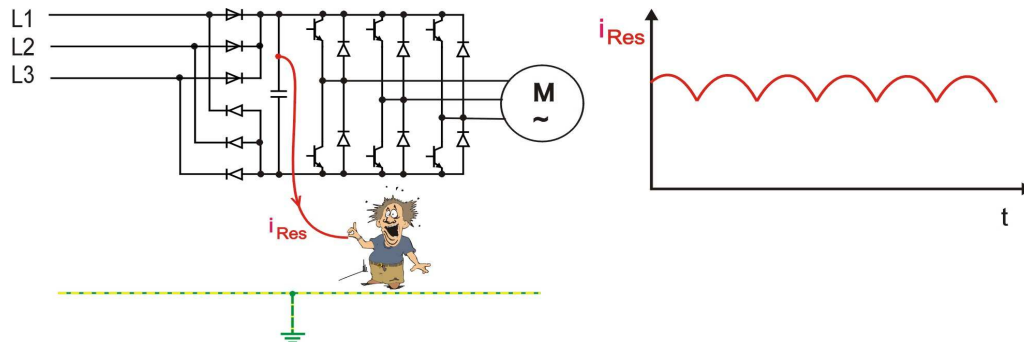

This smooth DC residual current* caused by the B6 connection at the input of the FC would not cause conventional residual current circuit-breakers (RCCBs) of Types A or AC to trip.

This is because there is no time-variant magnetization in the totalising current transformer of the residual current circuit-breaker, such as would be required for the inductive energy transfer to the tripping relay of the RCCB.

Depending upon its strength, the DC residual current causes instead a pre-magnetization of the transformer core and thereby raises the tripping threshold of the RCCB for any other AC residual currents which might be present up to the point of no tripping at all.

* (A more detailed explanation of how the DC residual current arises from the three individual currents of phases L1, L2, and L3 is to be found in Appendix A.)

2. What are Residual Currents and what are Leakage Currents?

Residual currents are mainly ohmic and arise through faulty insulation between live components and earth, e. g. due to accumulated dirt and moisture in a device. Another example would be a short to earth, when a person directly touches a phase of the mains (see Fig. 2a).

Leakage currents are often capacitive and flow e. g. because of measures for interference elimination via the capacitors in EMC filters, or via the capacitance of long shielded cables, to earth (see Fig. 2b). Depending upon the application and the electrical installation, residual currents as well as leakage currents may consist at one and the same time of several frequency constituents differing markedly from the 50 Hz mains frequency.

An RCCB cannot distinguish between residual currents and leakage currents and therefore rates them equally. Hence circuit-breakers could already be tripped if the total of all leakage currents present exceeds the tripping threshold of the RCCB, although no fault (residual current) has occurred in the electrical installation.

Fig. 2a:

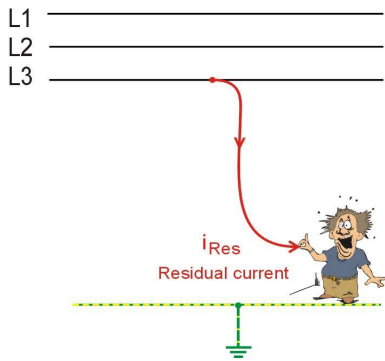
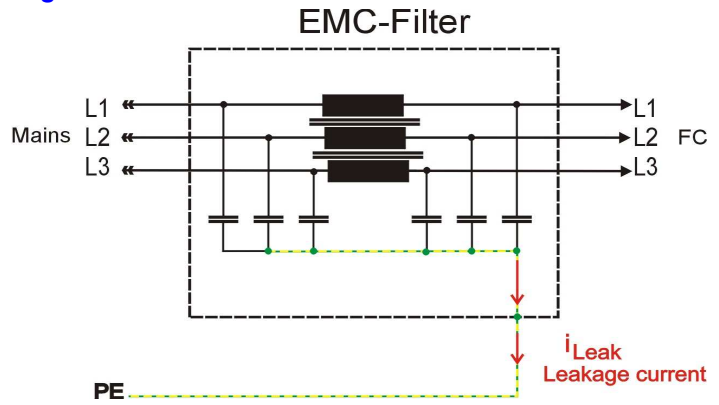

Fig. 2b:



3. Which Residual Currents can arise in Frequency Converters:

Here are some examples of possible residual currents in an installation with an induction motor which is operated with a frequency converter (FC)

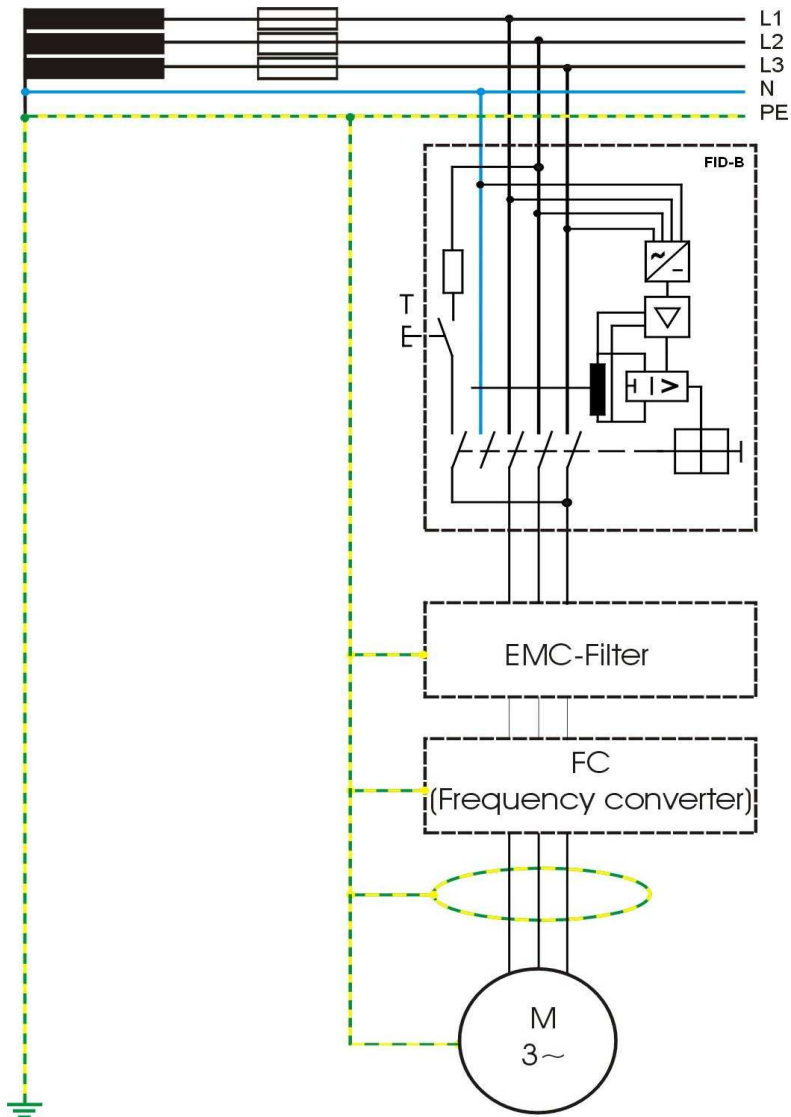
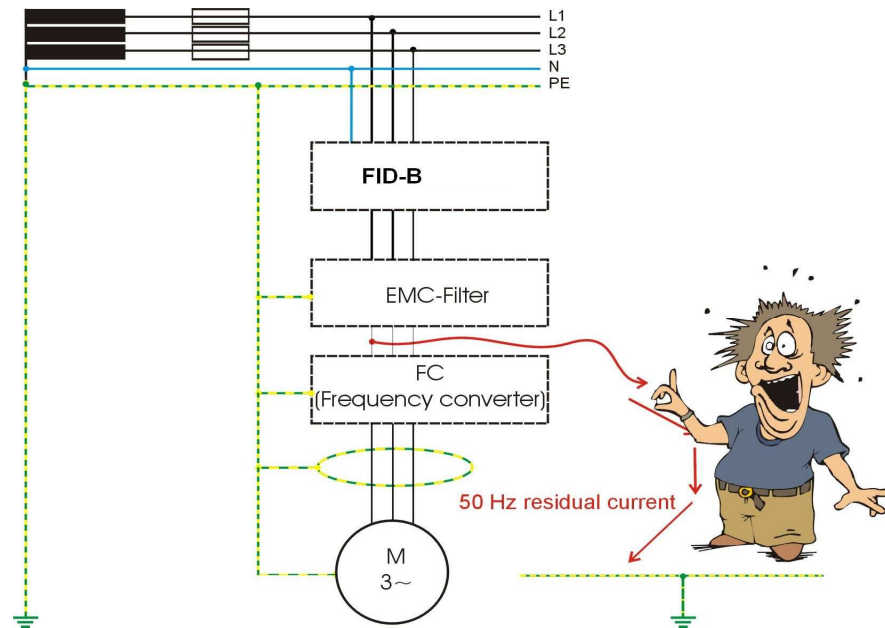
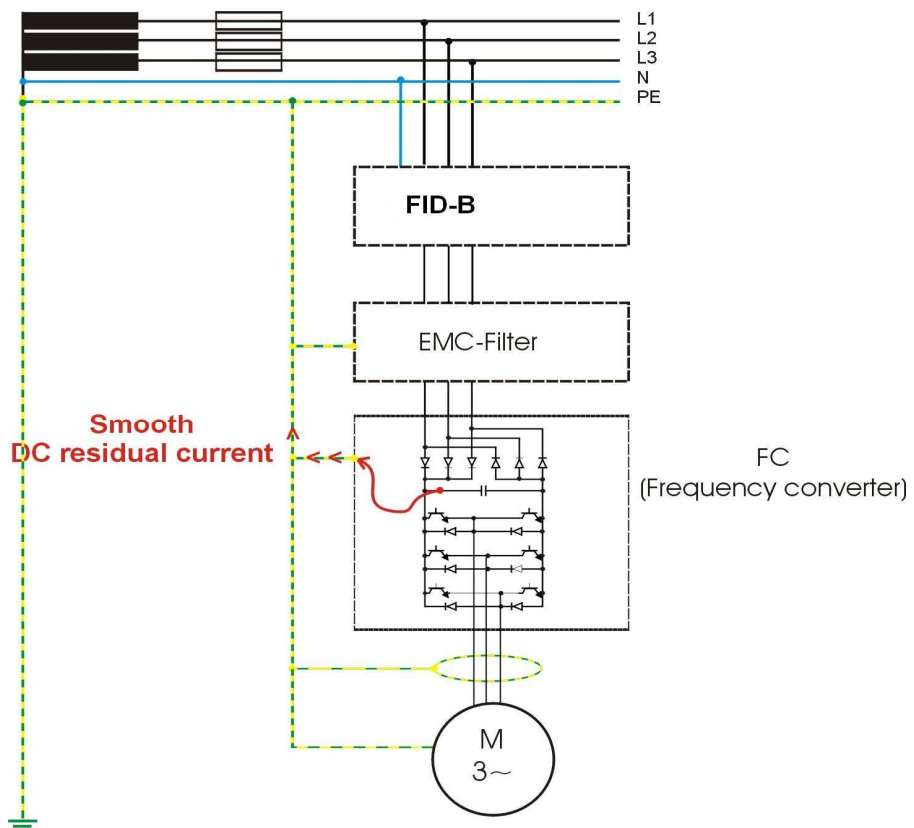

Fig. 3a: A person touches conductor L1 at the input of the frequency converter



A full sine 50 Hz residual current passes through the body of the person. If the strength of this residual current is high enough the RCCB will reliably be tripped

Fig. 3b: Defective insulation between the +pole of the indirect capacitor and the housing of the frequency converter



Such a fault could be due to e.g. the effect of dust and moisture penetration. In this instance an all but smooth DC residual current will flow. An AC-DC sensitive circuit-breaker will certainly be tripped when the relevant DC residual current strength is reached.

Fig. 3c: A person directly touches L1 of the motor's supply cable

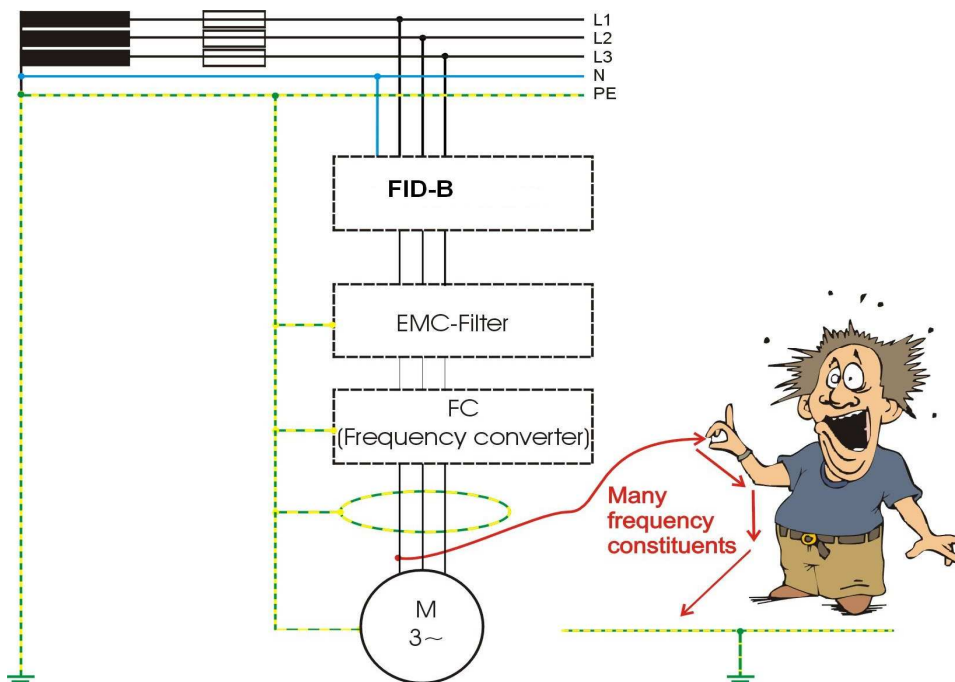

Example: A motor is run with an initial frequency (also known as machine or motor frequency) of 10 Hz. The operating frequency (also known as chopper frequency) of the FC is 8 kHz. While the unit is in operation the person touches the conductor L1 of the faulty supply cable of the motor. Through the body of the person there will now pass a residual current consisting of many frequency constituents. In addition to the initial frequency of 10 Hz with a lesser amplitude, it will also contain the 8 kHz operating frequency of the FC which, together with its harmonics* 16 kHz, 24 kHz, 32 kHz etc., will form a considerable part of it.

* (How harmonics arise is more fully explained in Appendix B)

For currents with frequencies in excess of 1 kHz passing through a body the danger point for causing fibrillation of the human heart is over 400 mA. However, a high residual current may also cause thermal injuries to the body. A residual current circuit-breaker, which is to protect people even when they are directly touching a live component, must therefore also have sufficient sensitivity in the frequency range above 1 kHz. For this reason our AC-DC sensitive RCCBs in the FID-B model ranges reliably detect residual current constituents with frequencies up into the MHz range at sufficient sensitivity. Thus the protection level (protection in the event of indirect contact, fire protection or protection in the event of direct contact), as denoted by the residual current rating, is provided over the whole frequency range.

4. Which Leakage Currents can arise?

We differentiate between stationary, variable and transient leakage currents. To explain these we are once again using the example of an installation with an induction motor operated with a frequency converter (FC).

Fig. 4:

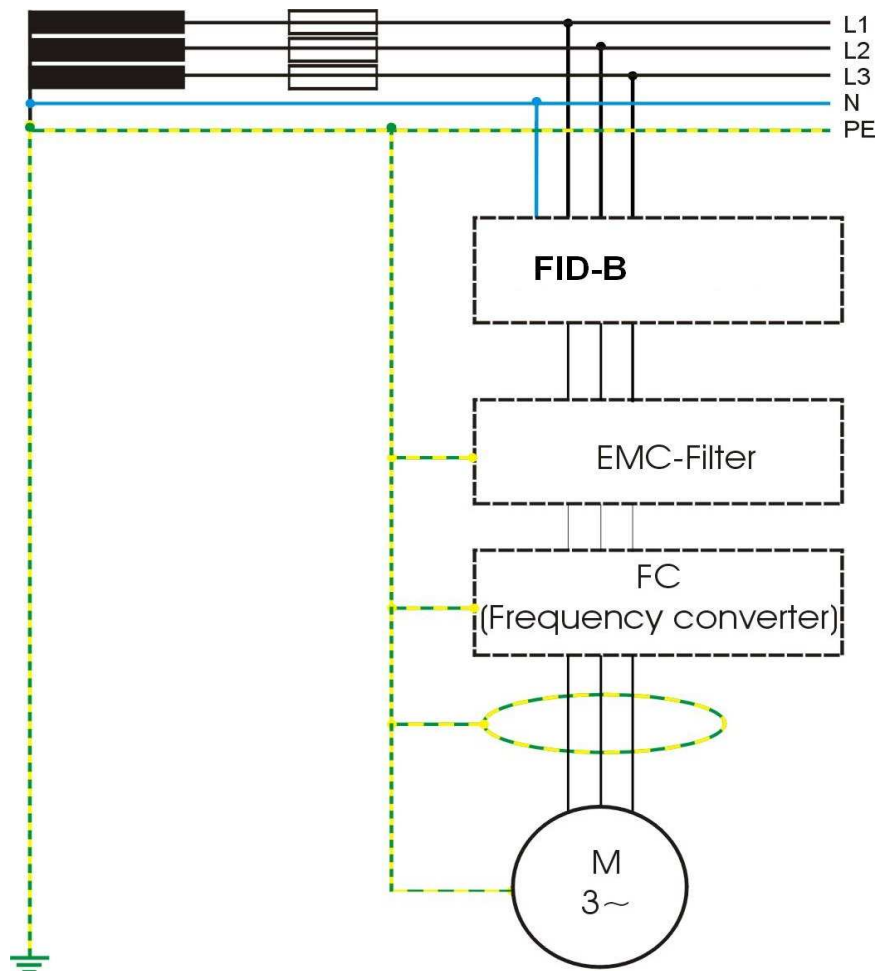

In order to meet the applicable EMC regulations (Electromagnetic compatibility) the FC may only be operated via a series-connected EMC filter, which may already be integrated in the FC. Because the pulse-width modulated output voltage of the FC is extremely sharp edged, and therefore contains harmonics with high amplitudes and frequencies, the motor may only be connected to the FC via a shielded cable if it is to meet EMC regulations.

Stationary leakage currents:

An EMC filter in its most basic form consists of LC low-passes whose capacitors are star connected to the protective earth. With ideal mains conditions providing a strictly sinusoidal voltage, the total of all capacitive currents passing through these capacitors is zero. But because of the marked distortions of the mains voltage prevalent in practice, a total capacitive current is encountered which is not zero, which is continually discharged via the earth conductor, and which is therefore termed stationary leakage current. As a result of the B6 bridge connection at the input of the FC, leakage currents are also generated through the internal capacitors of the EMC filter. The stationary leakage current is present even if the motor is not running (regulator inhibit of the FC) and typically has frequency constituents of 100 Hz to 1 kHz and may have an amplitude of several hundred milliamperes. Particularly simple and cheap EMC filters with little inductivity and large capacitors cause high leakage currents and can result in unwanted tripping of the residual current circuit-breaker.

Note on the use of single-phase operated FCs:

Single-phase operated frequency converters are frequently equipped with an integrated EMC filter. With this type of filter the filter capacitors are connected from L to PE and N to PE. This leads to not insubstantial 50 Hz leakage currents arising here. When employing several FCs care should be taken to ensure that these are distributed as evenly as possible over the three phases to compensate for the leakage currents and thus prevent the residual current circuit-breaker from tripping.

Variable leakage currents:

If the speed of the motor is regulated by the FC, then additional frequency constituents of over 1 kHz arise within the total leakage current. The switching frequency of the FC in particular (typical values: 2, 4, 8, 16 kHz) and also the associated harmonics are present with very high amplitudes. A long motor cable with earthed shielding acts like a capacitor which is connected to earth, and thus discharges to earth currents of corresponding frequency plus their harmonics.

The course of stationary and variable leakage currents is nearly cyclic when the motor speed is constant. A residual current circuit-breaker reacts to these leakage currents by cutting off when, at the respective frequency, their strength exceeds the tripping threshold of the RCCB. Changes in the motor speed also bring about a change in the variable leakage currents - in the frequency spectrum as well as in the amplitude - and could then cause the RCCB to trip. In order to avoid unwanted tripping it is possible to design the AC-DC sensitive RCCB so that it is generally insensitive to residual currents in the frequency range of the leakage currents. However, if residual currents within this frequency range may occur, the protection level provided will be restricted by this measure!

Transient leakage currents:

Due to inductances in the current paths any switching-off processes give rise to voltage peaks in the mains. These contain very high frequency constituents because of the steep leading edges of the peaks. In addition, by switching on when the phase angles of the mains voltage are unfavourable, the spectrum of the mains voltage will temporarily contain some high-frequency constituents due to the high-speed voltage increase.

These high-frequency voltage constituents discharge to earth transient currents via the above mentioned capacitors of the EMC protective measures, which may cause unwanted cut-off by RCCBs.

When mains voltage is hooked up using switches without a high-speed switch function, the three phases will be connected offset in time from each other depending upon the switching speed. So long as not all three conductors are live, an increased leakage current will be discharged to earth via the EMC filter's capacitors of those wires which are already connected.

Spurious tripping as a result of transient leakage currents can often be avoided by using RCCBs with response delay feature. In order not to impair the protective property beyond the acceptable, the delay may only be effective within narrow limits. This means that the RCCB cannot arbitrarily be "immunized" against transient leakage currents. RCCBs in the FID-B model ranges feature such a response delay. However, should the transient leakage currents exceed the maximum permissible breaking time of the RCCB as stipulated in the regulations, then tripping will take place at the relevant current strength nevertheless!

5. Measures for reducing Leakage Currents:

As explained above, giving an RCCB the ability not to respond to leakage currents is in most cases to the detriment of its protective effect. It is therefore recommended that leakage currents be reduced to a minimum by adopting the following measures.

5.1. Reducing Stationary Leakage Currents

- Many manufacturers of FCs are now offering low leakage current EMC filters. The design of this type of filter ensures that considerably lower leakage currents are generated than with standard filters
- In electrical nets which include a neutral conductor, a 4-wire filter can be employed. This type of filter offers the lowest leakage currents. (The main share of the leakage currents being now discharged via Neutral).
- Under no circumstance may a single-phase load, e. g. an incandescent lamp, be connected at the output of a three-phase EMC filter (without neutral connection) to the neutral wire elsewhere in the system! The unbalanced load of the filter would further increase the leakage currents, and the effect of the filter be substantially impaired, so that the permissible limits for meeting EMC regulations will clearly be exceeded.
- If several single-phase operated frequency converters are being employed, then they should be distributed evenly over all the phases.

5.2. Reducing Variable Leakage Currents:

- Keep the shielded motor supply cable as short as possible.
- Install sine filters, EMC sine filters or output chokes directly after the output of the FC (before the motor supply cable). By reducing the steepness of the edge of the FC's output voltage they significantly lower any leakage currents in excess of 1 kHz at the cable supplying the motor.
- If several FCs with built-in filter are being used, then the variable leakage current can be significantly reduced by adding a joint 4-wire filter.

5.3. Further Reduction of Leakage Currents:

- Power chokes which are located upstream of the EMC filter reduce the current ripple, including harmonics, and increase the lifespan of the FC's components.
- In electrical installations comprising several FCs one collective filter should be used instead of individual EMC filters for each FC. Thus the sum of the leakage currents from all individual filters is usually higher than the leakage current arising from one larger joint filter.
- If several FCs are employed in an electrical installation care should be taken that they are not all run up simultaneously. With simultaneous enabling of the regulators of several FCs, high and cumulative leakage currents will temporarily arise which might result in unwanted tripping.

Note:

The filters described in this section are normally available as accessories from manufacturers of electronic equipment (frequency converters, rectifiers etc.). Such sources would also be able to answer any queries of a more detailed technical nature.

5.4. Reducing Transient Leakage Currents when an Electrical Installation with Electronic Equipment is switched on or off:

As has already been mentioned above, filters must be used when operating electronic equipment in order to meet the EMC Regulations. These filters contain, e. g. in the case of a conventional 3-wire EMC filter, three capacitors star connected to earth. The majority of RCCBs contain a simple switching device. The temporal connection and disconnection of individual current paths depends upon the switching speed of the operator and may sometimes amount to a time difference of 10 - 20 ms. In this case the balancing of the three capacitors' star point is no longer provided and a considerable capacitive leakage current can pass via the protective earth, thus causing the RCCB immediately to trip again. For this reason connection and disconnection

should only be carried out with the aid of an additional high-speed switching device (e. g. disconnecting switch with quick-break function or all-pole switching contactor) and not with the RCCB itself.

In electrical installations with a large number of FCs it could happen, particularly when switching on, that in certain exceptional circumstances the RCCB is tripped even though connection was made with a high-speed switching device. In this case, due to the filter capacitors' not being charged, very high leakage currents arise over a period exceeding the maximum permissible breaking time of the RCCB. A joint EMC filter for several FCs can also markedly reduce the high residual current at making (see also Point 5.3).

5.5. Avoiding Increased Residual Currents with Spurious Oscillation of the EMC Filter:

With electronic equipment such as frequency converters there is normally a choice of switching frequencies (choppers). In some unfortunate instances this switching frequency can lead to the spurious oscillation of a series-connected EMC filter and thereby to excessively high leakage currents which cause the RCCB to be tripped. In such cases the switching frequency of the FC should be changed!

6. Correct use of AC-DC Sensitive Residual Current Protection in Electrical Installations with Electronic Equipment:

6.1. Regulatory Use of AC-DC Residual Current Control Devices:

If smooth DC residual currents (not touching zero) are to be expected due to the use of certain electronic equipment then, according to EN 50178 (Electronic equipment for use in power installations, Sections 5.2.11.2 and 5.3.2.3), AC-DC sensitive residual current control devices must be used. This applies e.g. to 3-phase operated FCs which at the input side normally employ a 6 - pulse bridge connection (Fig. 5) for rectifying the mains voltage.

Fig. 5:

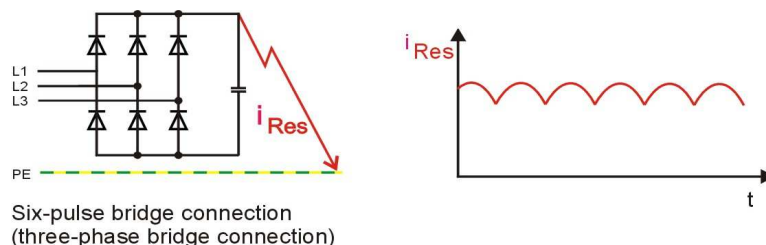

6.2. Differentiation in Circuits:

According to EN 50178, Sect. 5.3.2.3, it is not permissible for circuits with electronic equipment, such as FCs to be connected in series with control devices sensitive to residual currents of Type AC or A, because – as explained above – their function is impaired by smooth DC residual currents (premagnetization or magnetic saturation of transformer core).

Fig. 6:

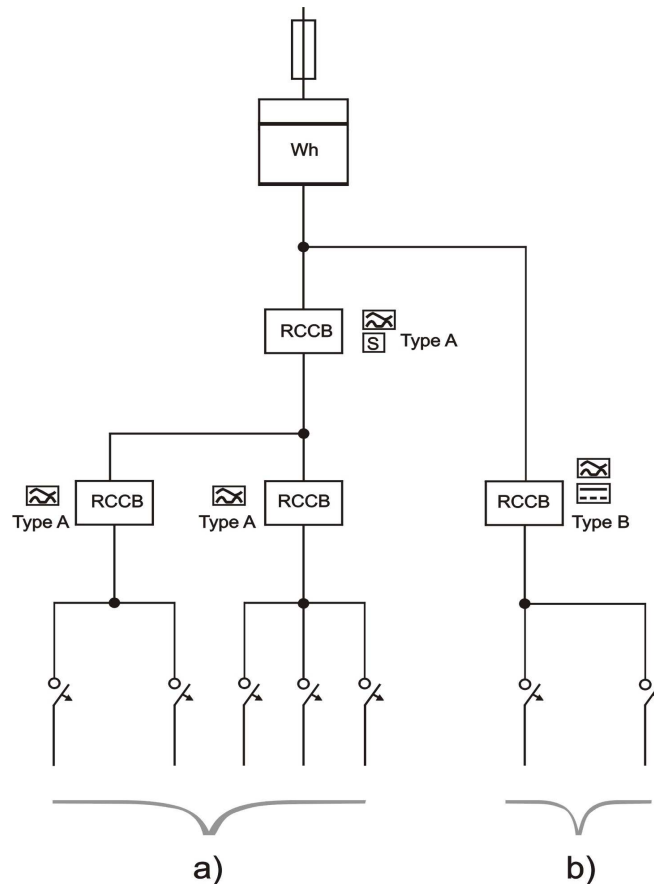

To Fig. 6:

a): Circuits with electronic equipment in which AC residual currents and / or pulsating DC residual currents may occur in the event of a fault.

b): Circuits with electronic equipment in which AC residual currents and / or pulsating DC residual currents and / or smooth DC residual currents may occur in the event of a fault.

6.3. Protective Measures when Operating Electronic Equipment on Building Sites:

Excerpts from VDE 0100 T704 (Provision of Power Installations on Building Sites) and BGI 608 (Selection and Operation of Electrical Installations and Electronic Equipment on Building Sites):

- Single-phase operated electronic equipment rated AC 230 V / 16 A may be operated via residual current control devices sensitive to pulsating currents with $I_{\Delta n} \leq 30 \text{ mA}$ or disconnecting safety transformers if smooth DC residual currents are not to be expected. Smooth DC residual currents cannot pass via a single-phase bridge rectification in the event of a short to earth, even if the bridge section is fitted with a filter capacitor. But if the electronic equipment features half-wave rectification with a filter capacitor at the input side then smooth DC residual currents may arise if a short to earth occurs.
- Three-phase operated electronic equipment with $\leq 32 \text{ A}$ plug-in connection may only be operated via AC - DC sensitive control devices with $I_{\Delta n} \leq 30 \text{ mA}$ or disconnecting safety transformers.
- Three-phase operated electronic equipment with $> 32 \text{ A}$ to 63 A plug-in connection may only be operated via AC - DC sensitive control devices with $I_{\Delta n} \leq 500 \text{ mA}$ or disconnecting safety transformers.
- Three-phase operated electronic equipment with $> 63 \text{ A}$ plug-in connection may only be operated via AC - DC sensitive control devices or disconnecting safety transformers.

- Integrally attached electronic equipment without plug-in facility may be operated without residual current control devices or disconnecting safety transformers, however the safety measures stipulated in DIN VDE 0100 - 410 must be observed.

Appendix A:

Composition of DC residual current comprising the three individual currents of phases L1, L2 and L3:

Fig. 7a: Simplified diagram of a three-phase circuit with B6 bridge connection of the FC and a fault in the insulation

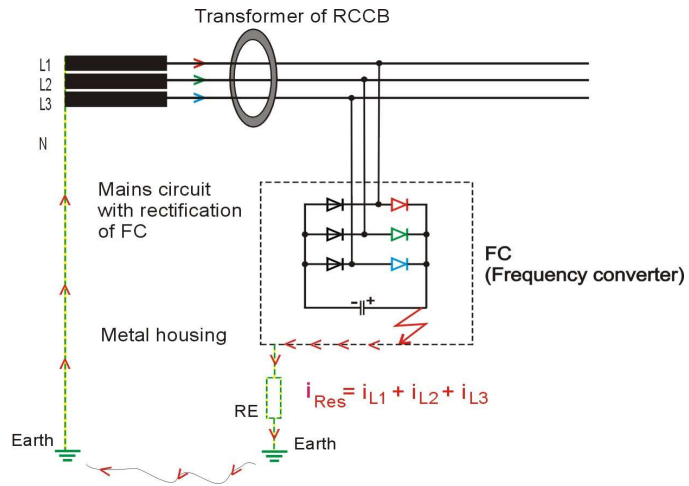
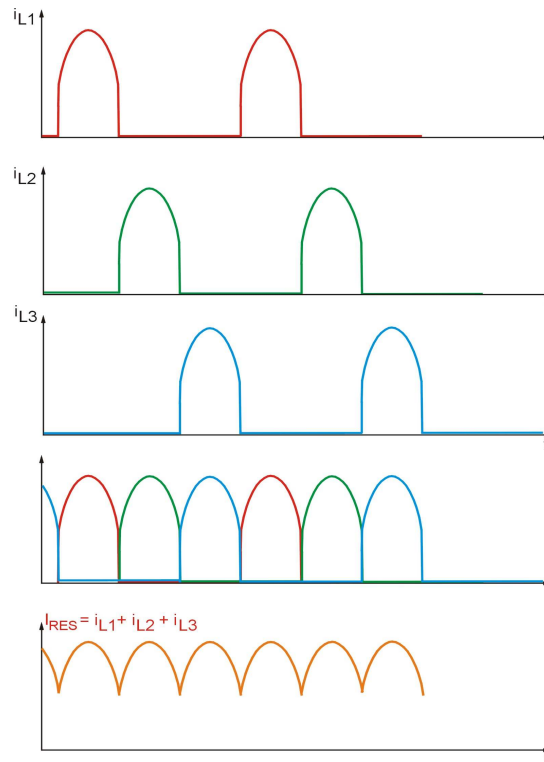

Fig. 7b: Illustration of individual conductor currents and the resultant residual current



The residual current i_{Res} results from adding the individual currents i_{L1} , i_{L2} and i_{L3} in the three phases L1, L2 and L3. The individual conductor currents i_{L1} to i_{L3} are pulsating DC residual currents with prolonged zero contact resulting from the commutation of three of the 6 rectifier diodes.

Their individual magnetic flux will be added together in the transformer core. The total is a magnetic flux with a high DC share which is nearly proportional to the residual current i_{Res} and which, in turn, causes premagnetization of the core and severely limits, possibly even prevents, further AC magnetization by any AC residual currents which might be present.

Appendix B:

Fundamental Oscillation and Harmonics:

The most basic oscillation, which mathematically cannot be broken down any further, is a sinusoidal wave (Fig. 8a). The frequency spectrum contains only a single frequency: The fundamental oscillation f_1 (Fig. 8b). If this sinusoidal oscillation were to be reproduced via an amplifier, it would sound very soft. A square-wave oscillation in contrast is very different (Fig. 9a). Reproduced by an amplifier this oscillation with the same fundamental f_1 sounds rather harsh and striking. It is evident when looking at the frequency spectrum (Fig. 9b) that, in addition to the fundamental oscillation, there are also several harmonic oscillations (harmonics for short). The square-wave oscillation is therefore composed of the sinusoidal fundamental oscillation (with the highest amplitude) plus many sinusoidal harmonics. These harmonics are mathematical multiples of the fundamental oscillation. In the case of the square-wave only uneven multiples can be found. This series of harmonics continues with reducing amplitudes into infinity. (By pulse-width modulating the square-wave output voltage of an FC it is also possible to achieve even multiples in the frequency spectrum.)

Fig. 8a: Sinusoidal oscillation

Fig. 8b: Frequency spectrum

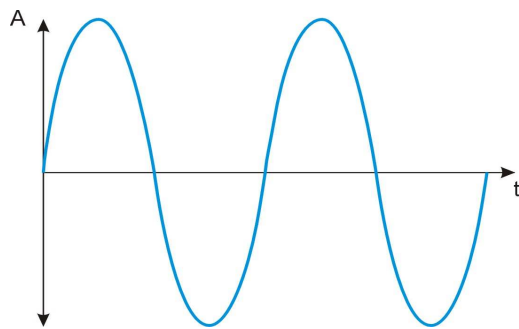
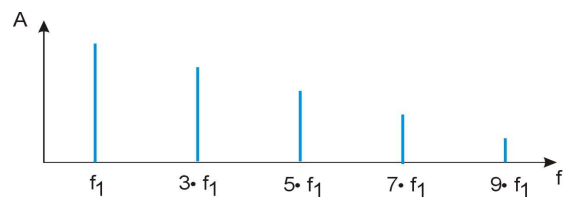
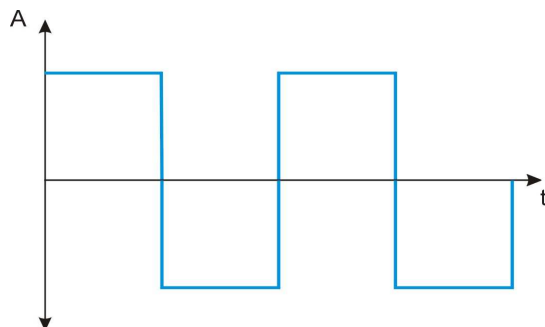

Fig. 9a: Square-wave oscillation

Fig. 9b: Frequency spectrum



Square-wave Output Voltages of the FC:

Fig. 1 shows a highly simplified representation of a frequency converter. Three pairs of transistors can be seen which, by means of switching processes, generate three output voltages for the motor. The transistors are connected to control electronics and generate a square-wave output voltage with a (mainly) constant frequency (switching or chopper frequency) at a variable pulse-width ratio. The output frequency (machine frequency) for the speed control of the motor is generated by changing the pulse-width ratio. Due to the high inductances of the motor windings, an all but sinusoidal current with the output frequency is generated in the motor. The switching frequency of the FC with the associated harmonics is audible in the motor as an unpleasant beeping sound. As a shielded supply cable acts like a capacitor, and due to the high square-wave output voltages of the FC, correspondingly high leakage currents with frequency constituents of the switching frequency and their harmonics are being generated.

Appendix C:

Product Range:

FID-B

DIN-rail mounted
70 mm installed width
according to EN 61008, IEC 61008
and VDE 0664 Part 100
40 - 80 amperes
Residual current: 0,1 A
0,3 A



FID-B S:

Selective
40 - 80 amperes
Residual current: 0,3 A

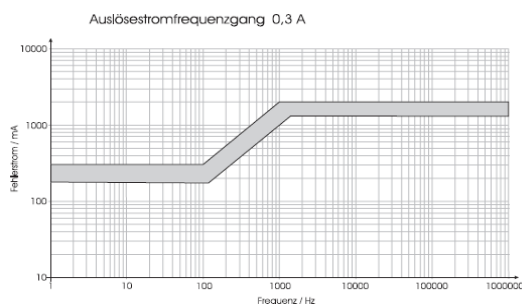
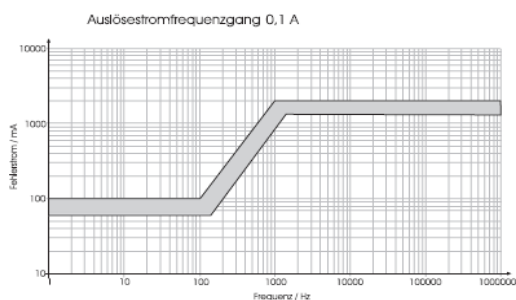

Order numbers:



RATED CURRENT / NO. OF POLES/ RATED FAULT CURRENT	DIM (W x H x D)	PU	TYPE	ORDER NO.
AC-DC sensitive Residual Current Circuit-Breakers				
40A/4/0,1A	72 x 85 x 69,5	1	FI-D/B 4/40/01-B	BD874110
63A/4/0,1A	72 x 85 x 69,5	1	FI-D/B 4/63/01-B	BD876110
80A/4/0,1A	72 x 85 x 69,5	1	FI-D/B 4/80/01-B	BD878110
40A/4/0,3A	72 x 85 x 69,5	1	FI-D/B 4/40/03-B	BD874130
63A/4/0,3A	72 x 85 x 69,5	1	FI-D/B 4/63/03-B	BD876130
80A/4/0,3A	72 x 85 x 69,5	1	FI-D/B 4/80/03-B	BD878130
SELECTIVELY AC-DC sensitive Residual Current Circuit-Breakers				
40A/4/0,3A	72 x 85 x 69,5	1	FI-D/B 4/40/03-SB	BD864130
63A/4/0,3A	72 x 85 x 69,5	1	FI-D/B 4/63/03-SB	BD866130
80A/4/0,3A	72 x 85 x 69,5	1	FI-D/B 4/80/03-SB	BD868130