

Condensatori in polipropilene metallizzato in custodia plastica serie 4.16.15

Metallized polypropylene film capacitors in plastic case series 4.16.15

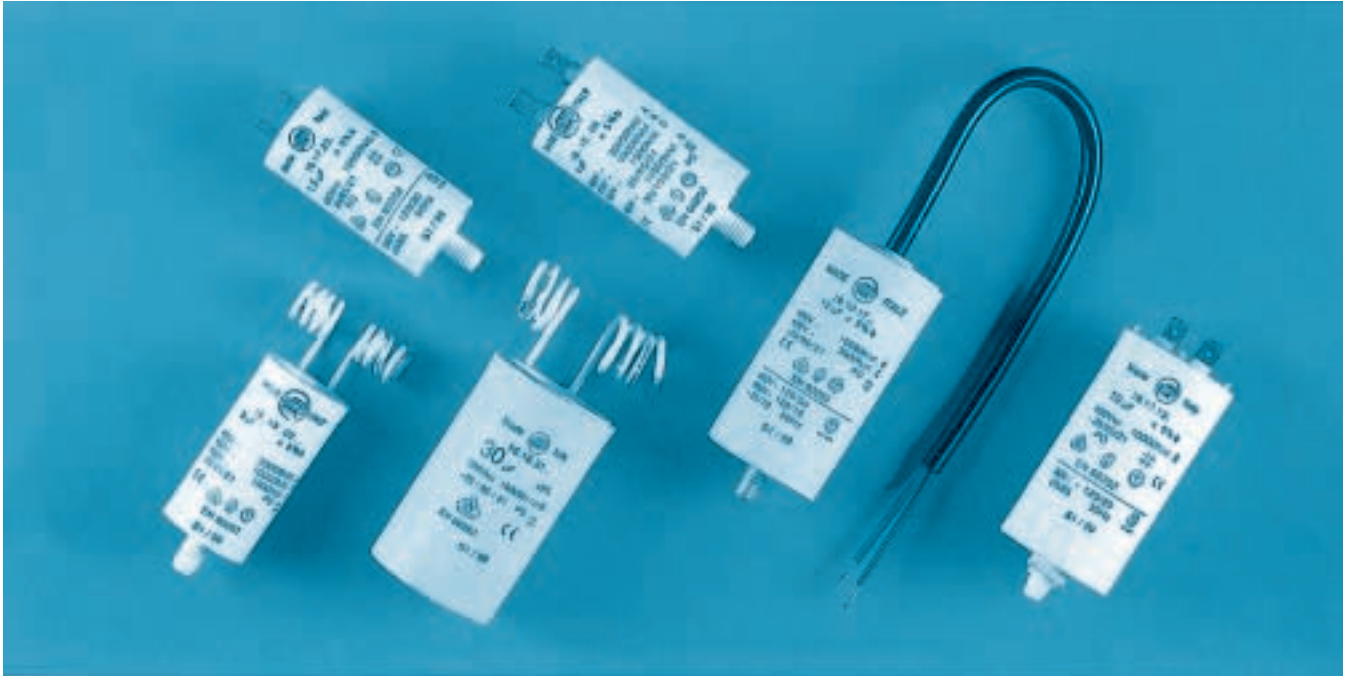

Il dielettrico è in film di polipropilene, le armature sono costituite da un sottilissimo deposito metallico ottenuto per evaporazione sotto vuoto.

Custodia e coperchio sono realizzati in materiale plastico autoestinguente: l'elemento capacitivo-sigillato con resina poliuretanic.

Le caratteristiche principali di queste serie di condensatori sono:





- Avvolgimento antinduttivo a basse perdite
- Proprietà autorigeneranti che impediscono il cortocircuito
- Piccole dimensioni e peso contenuto
- Il condensatore è assolutamente esente da rischi di perdite di liquido.
- classe di sicurezza: P0

The dielectric is polypropylene film, the electrodes consist of an extremely thin metal coating obtained by vacuum evaporation. Case and cover are made with self-extinguishing plastic material, the capacitive element is sealed with polyurethanic resin.

The main characteristics of these capacitors are:

- *Low losses non-inductive winding*
- *Self-healing property avoiding short circuits*
- *Small size and limited weight*
- *No leakage risk.*
- *Class of safety protection: P0*

Series 4.16.15

Omologazioni / Approvals					
Series 4.16.15	   				
	Tensione Voltage		Valori omologati Approved range		
	400 V ~	10000 h cl.B	25/100/21	0.5 ÷ 7,5µF	
	425 V ~	30000 h cl.A	25/85/21	0,5 ÷ 40 µF	
475 V ~	10000 h cl.B	25/85/21	0.5 ÷ 40 µF		
500 V ~	3000 h cl.C	25/85/21	0.5 ÷ 40 µF		
C (µF)	DxH (mm)	Part number 416.15.XX.KK	DxH** (mm)	Part number 416.15.XX.KK	
0,8	25x49	4.16.15.47.KK	28x55	4.16.15.30.KK	
1	25x49	.48.	28x55	.69.	
1,5	25x49	.50.	28x55	.67.	
2	25x55	.84.	28x55	.01.	
2,5	25x55	.85.	28x55	.28.	
3	30x56	.53.	28x55	.02.	
3,15	30x56	.54.	28x55	.66.	
3,5	30x56	.87.	32x55	.03.	
4	30x56	.88.	32x55	.04.	
4,5			32x55	.05.	
5	36x58	.06.	30x70	.98.	
6	36x70	.07.	30x70	.41.	
6,3	36x70	.29.			
7	36x70	.08.			
7,5	36x70	.09.			
8	40x70	.10.			
9	40x70	.11.			
10	40x70	.12.			
11	40x70	.13.			
12	40x92	.14.			
12,5	40x92	.15.			
13	40x92	.16.			
14	40x92	.17.			
15	40x92	.18.			
16	40x92	.19.			
17,5	40x92	.20.			
18	45x92	.21.			
20	45x92	.22.			
22	45x92	.65.			
25	45x117	.23.			
30	45x117	.24.			
31,5	45x117	.27.			
35	50x117	.25.			
40	50x117	.26.			
45	55x120	.74.			
50	55x120	.90.			
55	60x120	.94.			
60	60x120	.36.			
 UL recognition File E192559 400V~/500V~		Disponibile su richiesta Available on request			

** Dimensioni alternative / Alternative dimensions

Soluzioni meccaniche / Mechanical configuration

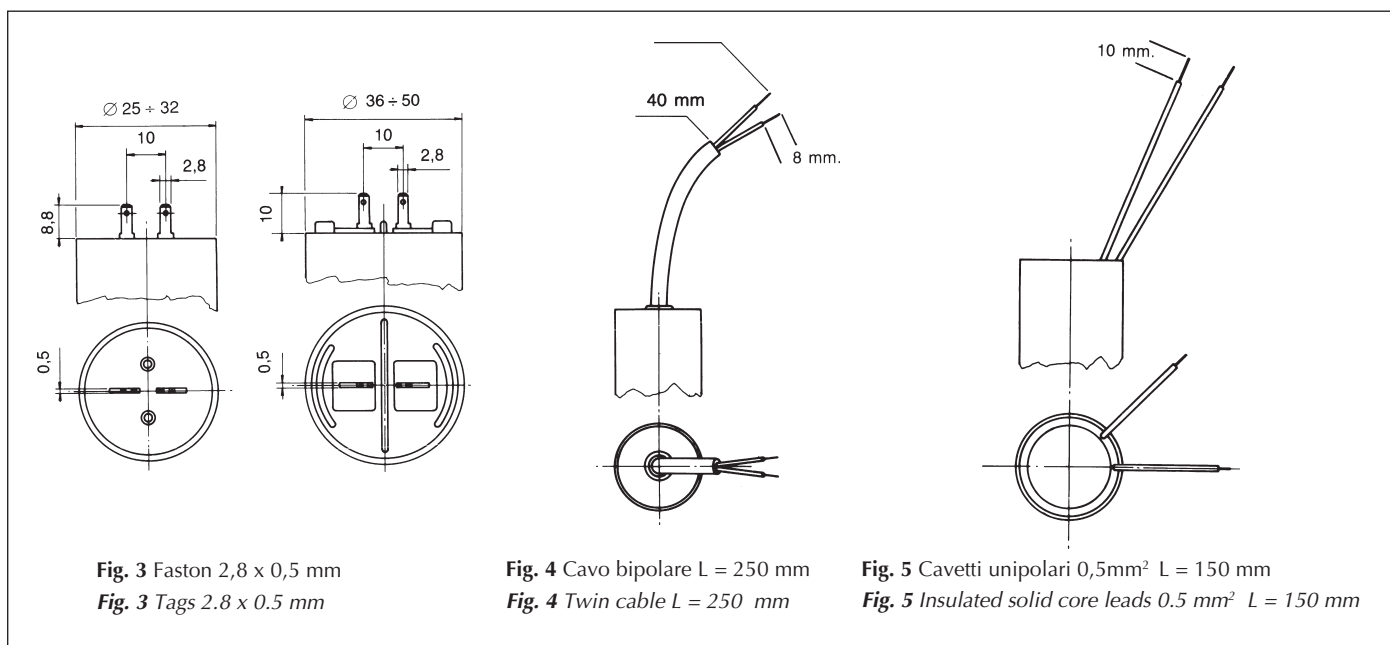
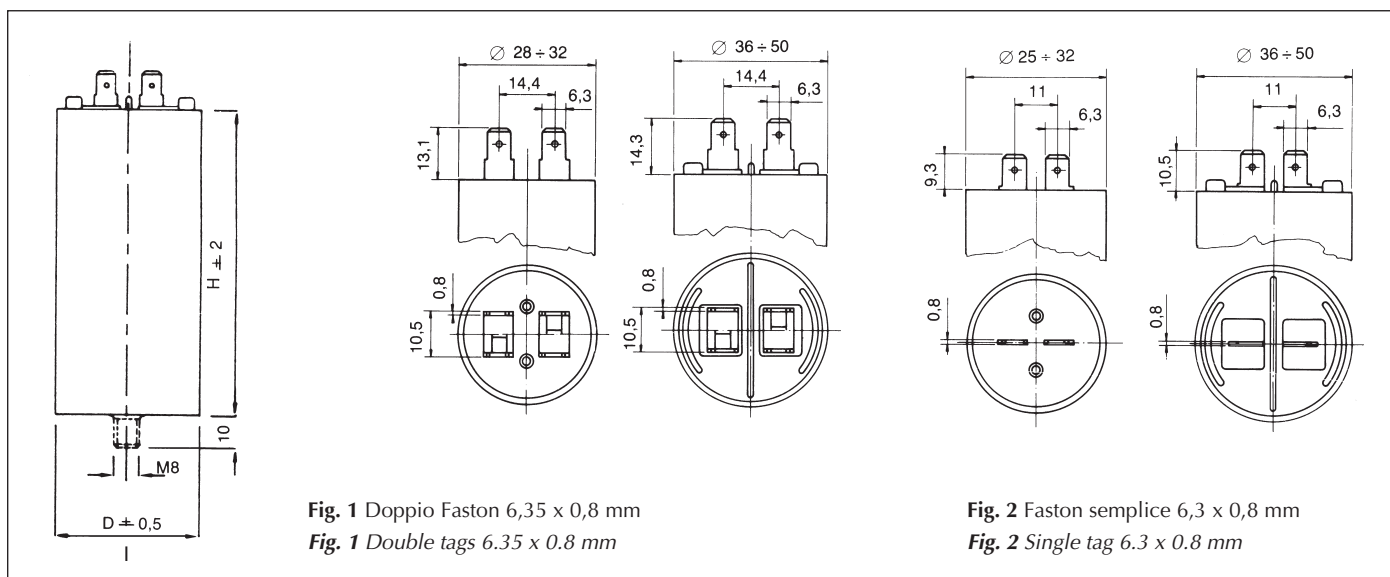

Accessori kk / Accessories kk *

Fig.	Descrizione Description	Serie - Series 4.16.18/.10/.17/.15		
		senza codolo without stud	con codolo with stud	fissaggio rapido fast fix
1	FASTON 6,3 mm doppio / double tag	60	64	71
2	FASTON 6,3 mm semplice / single tag	26	27	72
3	FASTON 2,8 mm a innesto / plug-in	00	40	
4	Cavo bipolare / twin cable L = 250 mm	10	14	
5	Cavetti unipolari / unipolar leads L = 150 mm	06	46	
Ø 28 e 32 Codolo M8 plastico / Plastic stud M8				
Ø 25, 30, 36 ÷ 60 Codolo M8 metallico / Metallic stud M8				

* Per i condensatori omologati UL, KK speciali.

* For UL recognized capacitors, different KK.

CARATTERISTICHE TECNICHE

Tolleranza di capacità	: $\pm 5\%$
Frequenza di lavoro	: $50 \div 60$ Hz
Tensione di prova individuale	: Fra le armature: $2,15 V_n$ per 2 sec; verso massa 3KV per 2 sec.
Angolo di perdita $\tan \delta$: $< 20 \cdot 10^{-4}$ @ 20°C $V=V_n$, 50Hz
Rivestimento	: Custodia e coperchio di chiusura in materiale plastico autoestinguente, grado V2 secondo UL 94
Terminali	: Terminali «Faston» 6,3 mm singolo, doppio, a innesto da 2,8 mm, cavo bipolare, cavetti unipolari
Grado di protezione	: Per esecuzione con terminali: IP00, per esecuzioni con cavo bipolare: IP55
Coperchio porta-terminali	: Test della sfera (IEC 309-1): 125°C Test del filo incandescente (IEC 695-2-1): 850°C Resistenza alle correnti superficiali (IEC 309-1): $\geq 250\text{V}$
Codolo filettato di fissaggio	: Coppia massima di serraggio: 5 N m

TECHNICAL CHARACTERISTIC

Capacitance tolerance	: $\pm 5\%$
Working frequency range	: $50 \div 60$ Hz
Individual test voltage	: Between terminals: $2.15 V_n$ for 2 sec.; between terminals and case: 3KV for 2 sec.
Dissipation factor $\tan \delta$: $< 20 \cdot 10^{-4}$ @ 20°C $V=V_n$, 50Hz
Protection	: Case and cover in self - extinguishing plastic material, grade V2 according to UL 94
Terminals	: Faston «terminals» 6.3 mm single, double, 2.8 mm plug-in, twin cable, unipolar leads
Protection degree	: with terminals: IP00; with twin cable IP55.
Cover	: Ball pressure test (IEC 309-1): 125°C Glow wire test (IEC 695-2-1): 850°C Tracking resistance (IEC 309-1): $\geq 250\text{V}$
Threaded fixing bolt	: Max torque: 5 N m

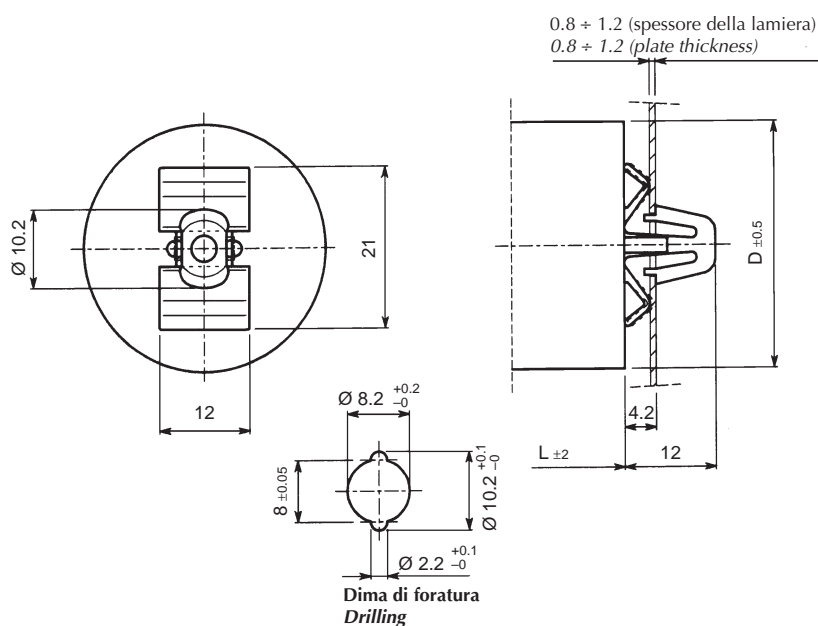

Fig. 6 Fissaggio rapido solo per dia 28, 32, 36, 40.

Fig. 6 Fast fix for dia 28, 32, 36, 40 only.

Fissaggio rapido "FAST FIX"

Il fissaggio "FAST FIX" (brevetto depositato il 3/11/1992, N° UD 92A000164) permette il montaggio rapido del condensatore sull'apparecchiatura ed è utilizzabile con lamiere di spessore compreso fra 0,8 e 1,2 mm. La foratura richiesta permette, comunque, il montaggio in alternativa dei condensatori con normale codolo filettato.

"FAST FIX" mounting system

The "FAST FIX" system (patent No UD 92A000164 registration date 3/11/1992) allows a quick mounting of the capacitors on the equipment and it is suitable for plates which thickness is between 0.8 and 1.2 mm. The required drilling allows, anyway, the alternative standard mounting by means thread stud.

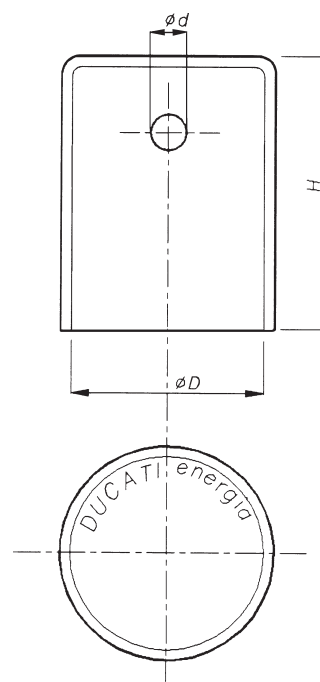

Fig. 7 Cappellotto.

Fig. 7 Protective cap.

Ø D	H	Ø d	Codice / P/n
28	50	8.5	316.23.0930
32	50	8.5	316.23.0940
36	50	8.5	316.23.0950
40	50	8.5	316.23.0960
45	65	8.5	316.23.0860