

Hand Lamp DL 026 Series with lamp holder

Long-life energy saving lamp

Versatile



Technical Data

Luminosity	1000Lm
Lamp type	energy saving lamp, E27 socket
Service life	10,000h
Connection	power cable (2m) with Euro plug
Mounting	screws or fixing plate (self-adhesive)
Casing	plastic according to UL94 V-0, light grey
Weight	approx. 0.60kg
Fitting position	variable
Operating/Storage temperature	-20 to +50°C (-4 to +122°F) / -45 to +70 °C (-49 to +158 °F)
Protection type / Protection class	IP20 / II (double insulated)
Approvals	-
Included in delivery	lamp holder, hook and fixing plate
Note	120VAC and DC voltages on request

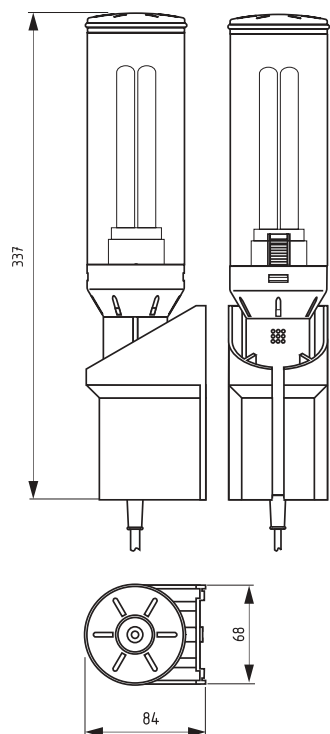

Art. No.	Operating voltage	Power consumption
02610.0-00	230VAC, 50Hz	20W (equals 100W light bulb)