



# CEP System

Cabur Electronic Protection

May 2007

# Why

## Characteristics of A, B, C, D mcb

	A	B	C	D	
T	$I_1 (t \geq 1h)^{1)}$	$1,13 \times I_n$	$1,13 \times I_n$	$1,13 \times I_n$	$1,13 \times I_n$
	$I_2 (t < 1h)^{2)}$	$1,45 \times I_n$	$1,45 \times I_n$	$1,45 \times I_n$	$1,45 \times I_n$
m	$I_4 (t \geq 0,1s)^{3)}$	$2 \times I_n$	$3,5 \times I_n$	$7 \times I_n$	$15 \times I_n$
	$I_5 (t < 0,1s)^{3)}$	$3 \times I_n$	$5 \times I_n$	$10 \times I_n$	$20 \times I_n$

T = sganciatore termico

m = sganciatore elettromagnetico

**Indicated values are in AC ; with DC currents  $I_4$  and  $I_5$  of instantaneous switch off of electromagnetic current really “m” must be multiplied x 1.4**

Curve I - t  
of thermal  
switch

Min I switch off

Max I swicth off

I for "sure switch  
off"

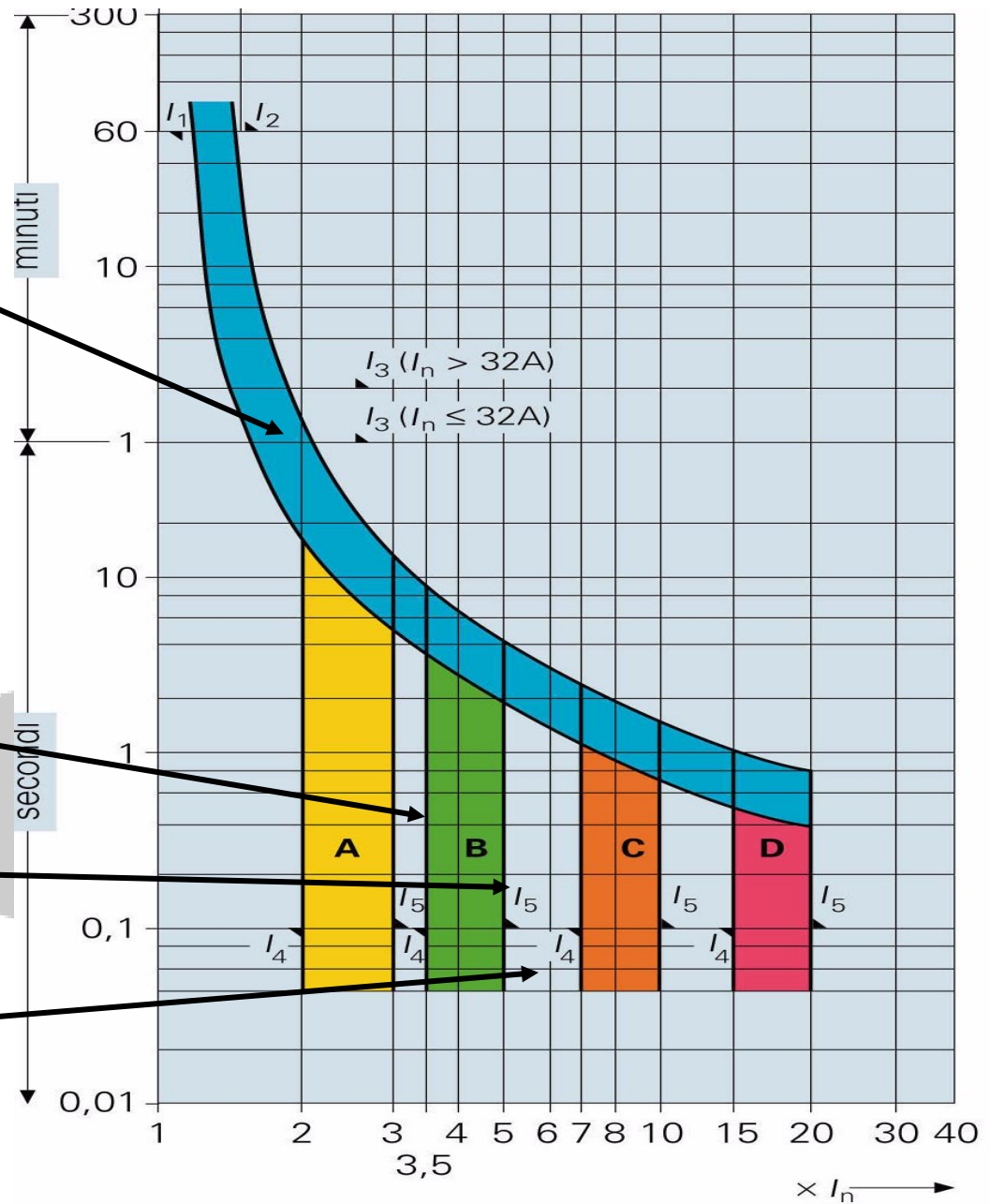

# CEP fast curve 3A : T with short circuit and overload

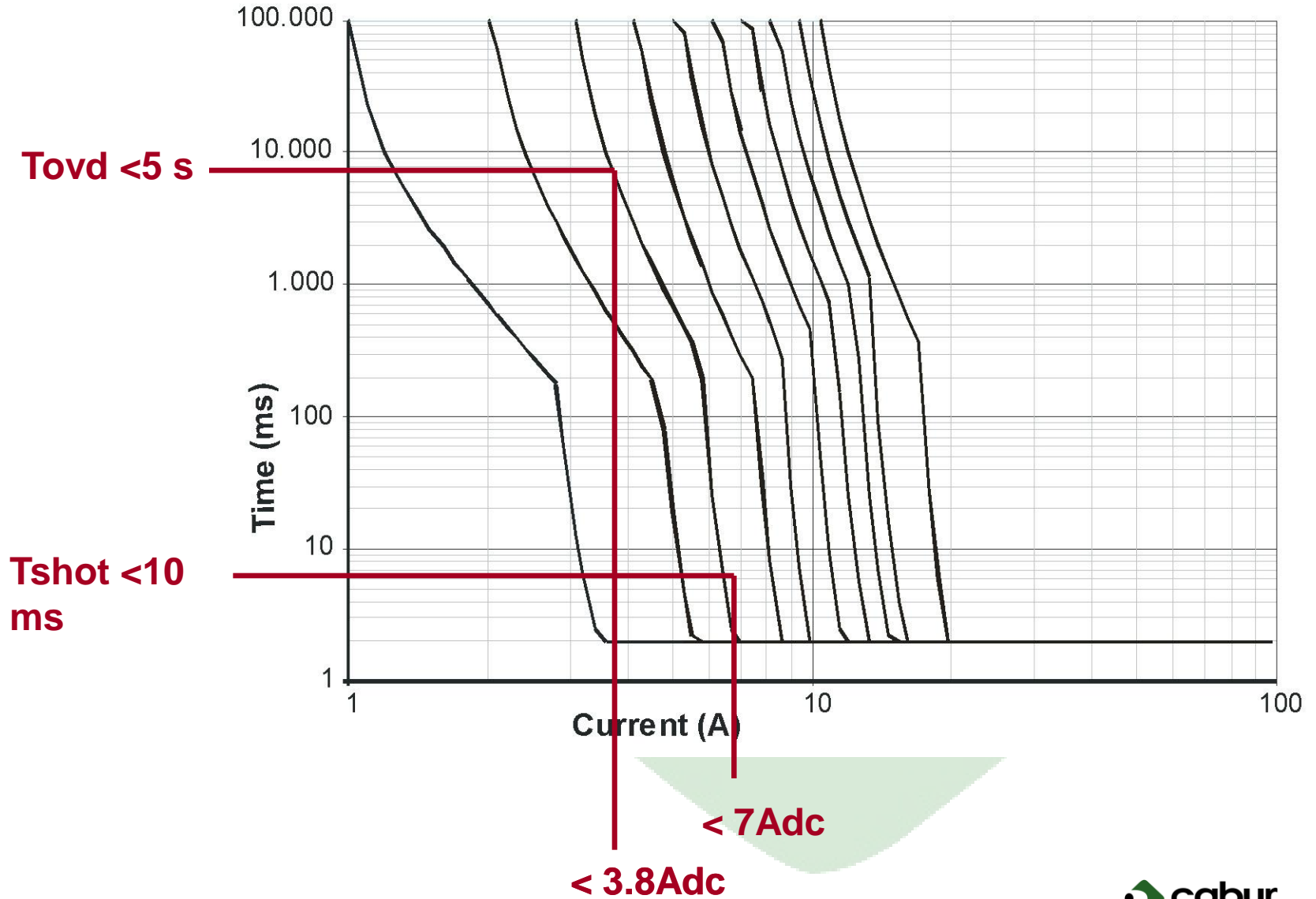

# CEP medium curve 3A : T with short circuit and overload

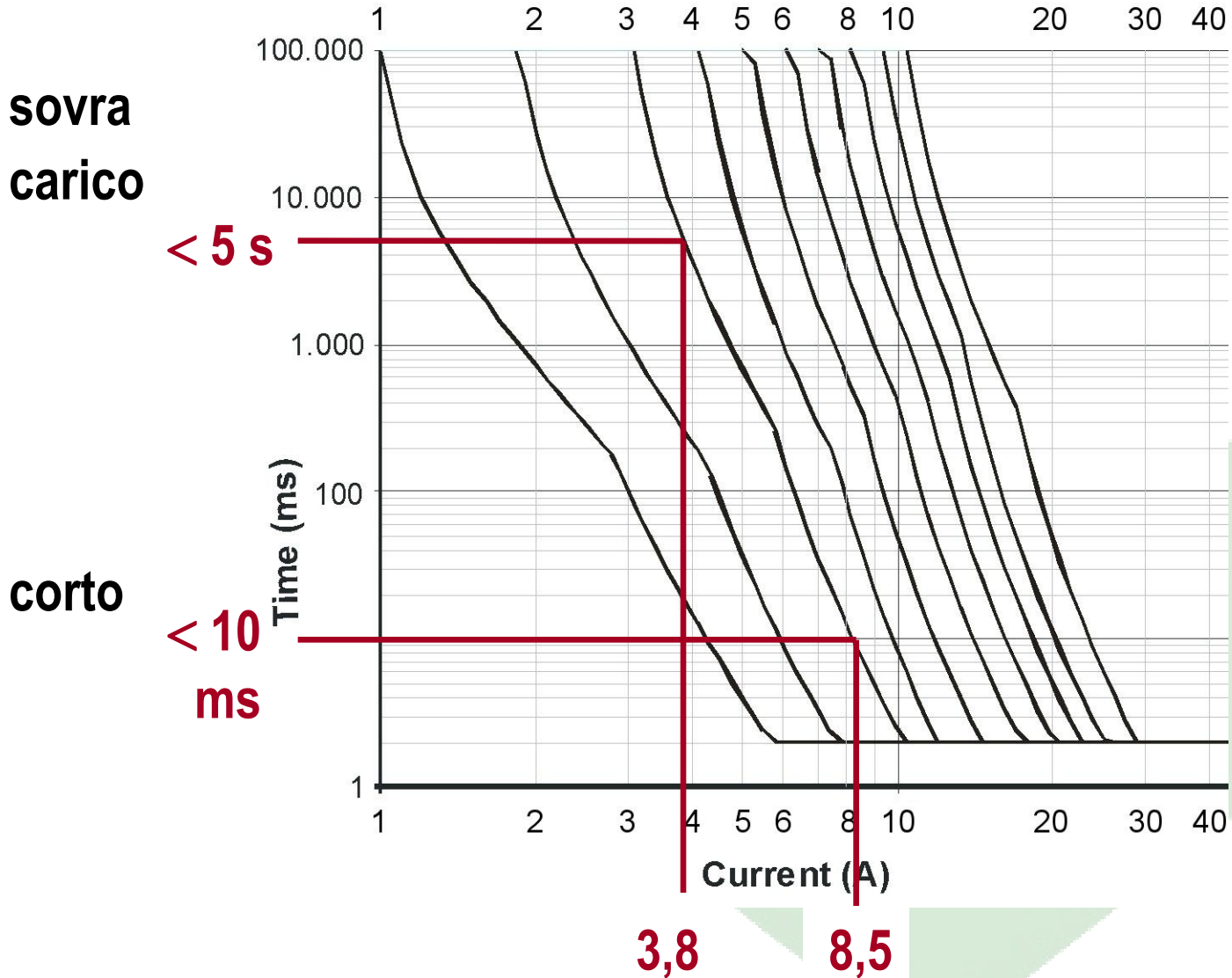

# CEP : the two curves in numbers

Curve	< 5 s overload	< 10 ms short circuit
B3	6 Adc	21 Adc
C3	6 Adc	42 Adc
CEP fast	< 4,5 Adc	7 Adc
CEP medium	< 3,8 Adc	8,5 Adc

# Three programmable curves

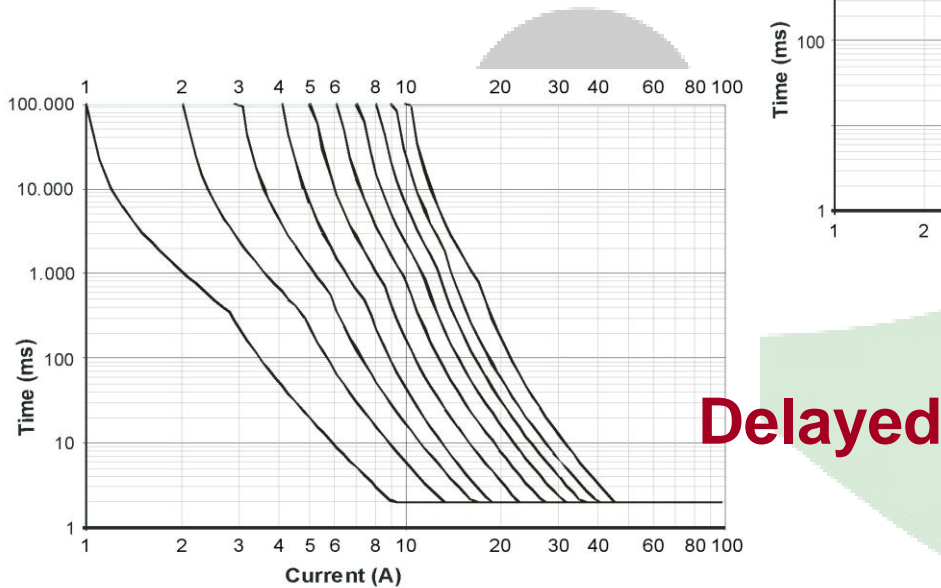
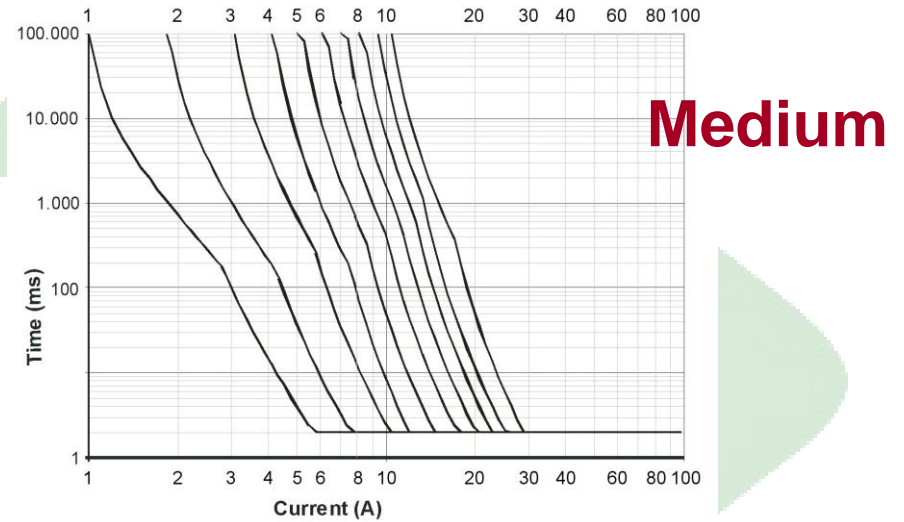
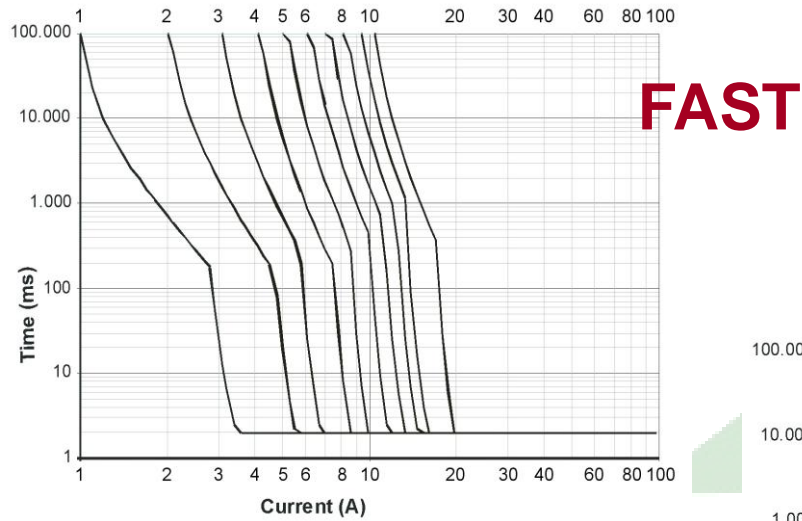

# The function

It is an electronic programmable fuse

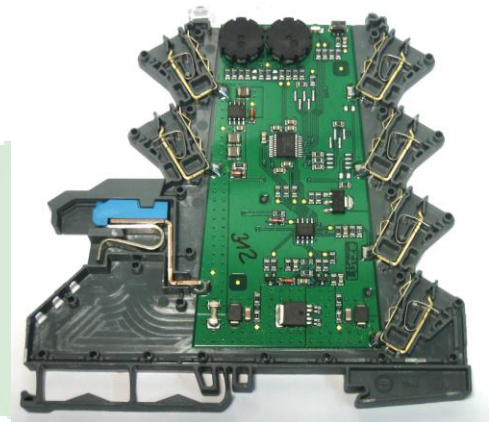
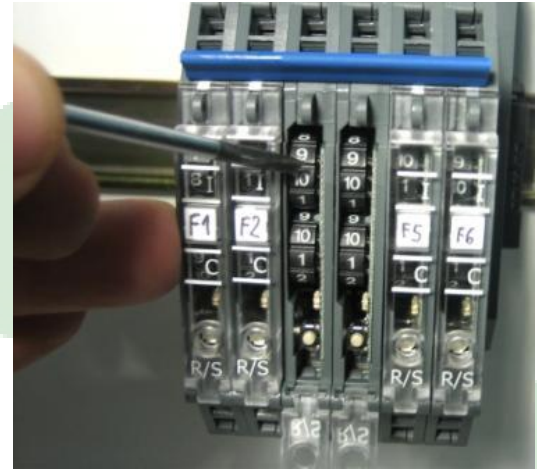

# Performances

**Max current DC 10A**

**Sealable front cover for set up protection**

**Programmable in 10 steps of 1A each**

**Possibilità marcatura**

**Caratteristiche (curve) programmabili  
(fast, medium, slow)**

**manual load ON/OFF switch**

**remote load ON/OFF command form PLC**

**LED display indicating OK / 90% of  $I_n$  / OVL**

# Functions

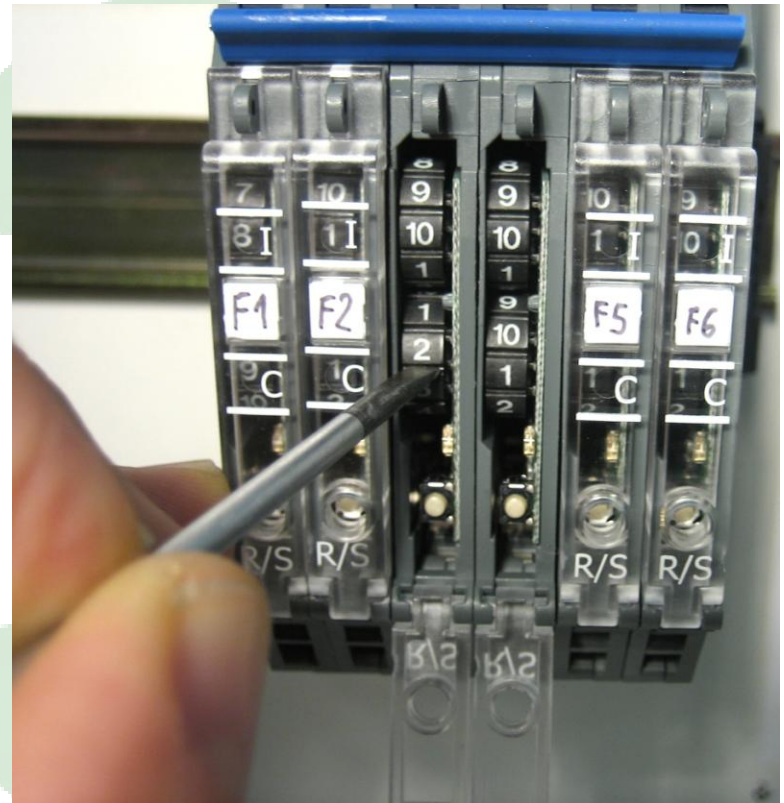
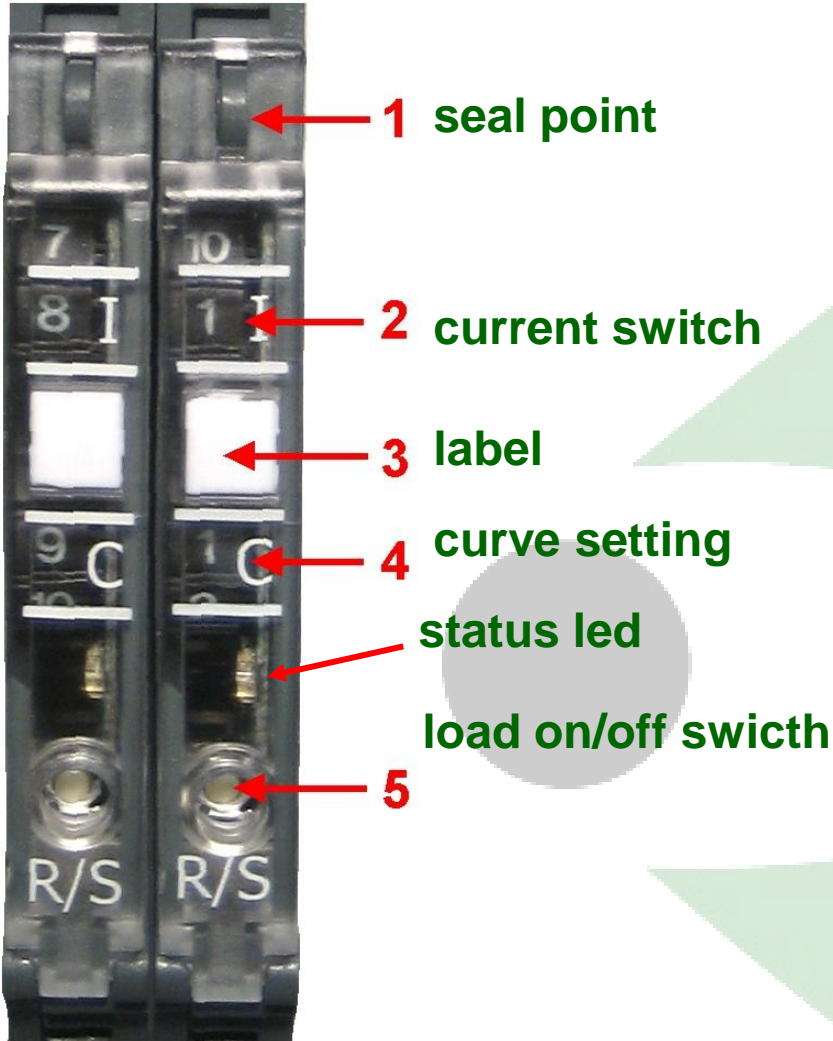

# Comfortable to use

- Can be used as a single or multiple module
- Can be replaced without stopping other CEP
- Load can be permanently switched off by a slide contact
- Local and remote status signal
- Memorization of the events

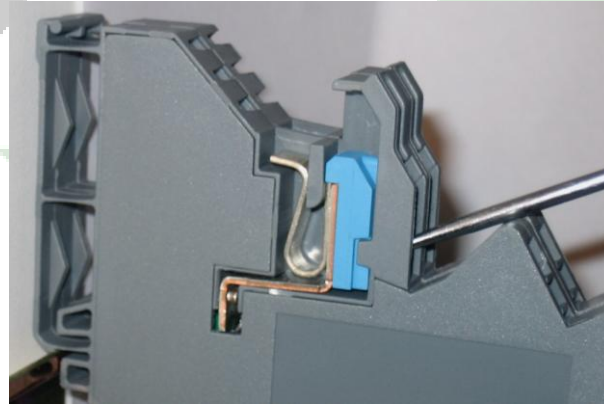

# Performances

Constant and accurate switch off current threshold not depending on ambient temperature

Can feed capacitive loads

the most compact : 8,1mm pitch

UL60950 approved



# How to connect CEP

The load negative wire must be feeded directly from the supply bus bar, not from CEP

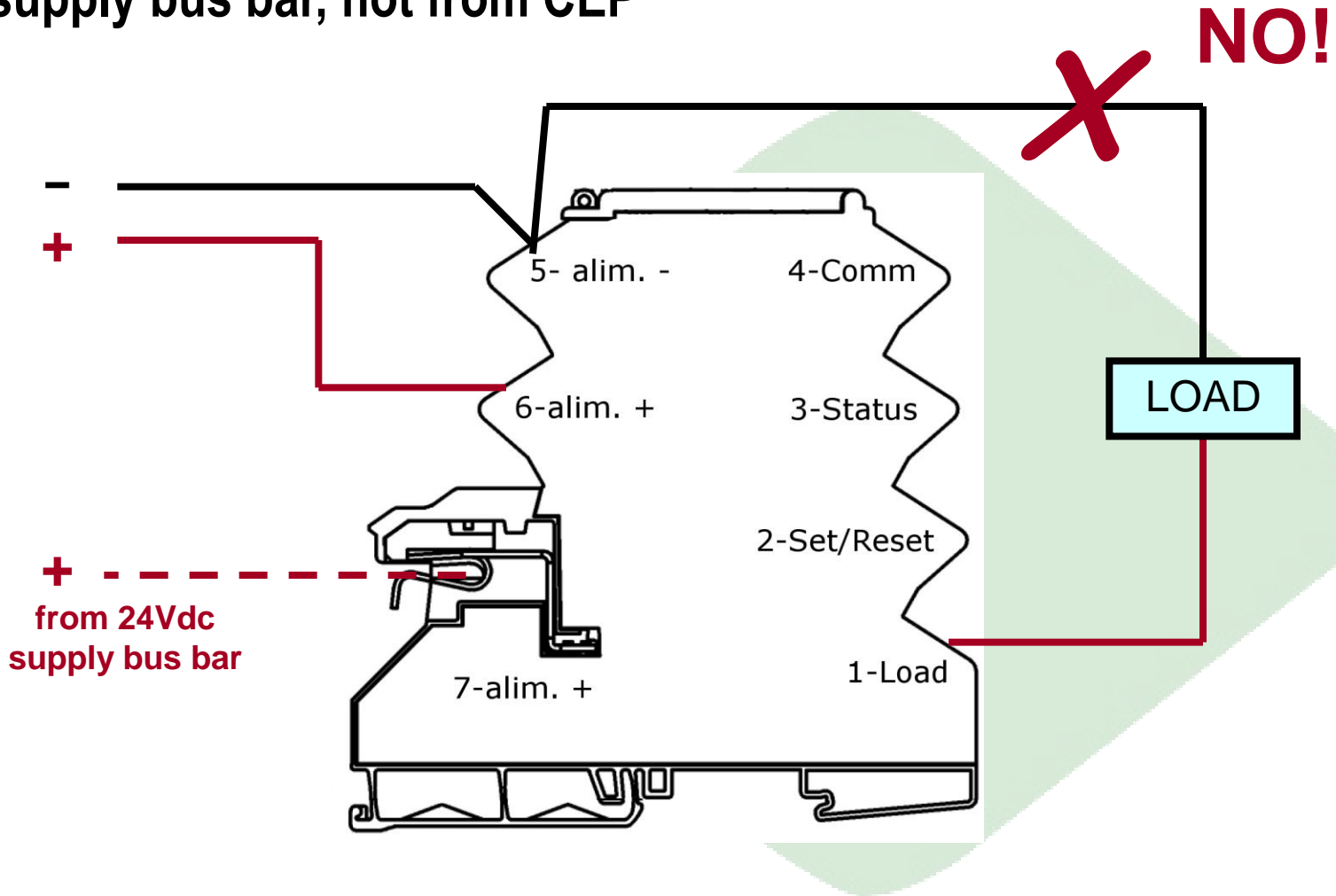

# How to connect CEP

The load negative wire must be feeded directly from the supply bus bar, not from CEP

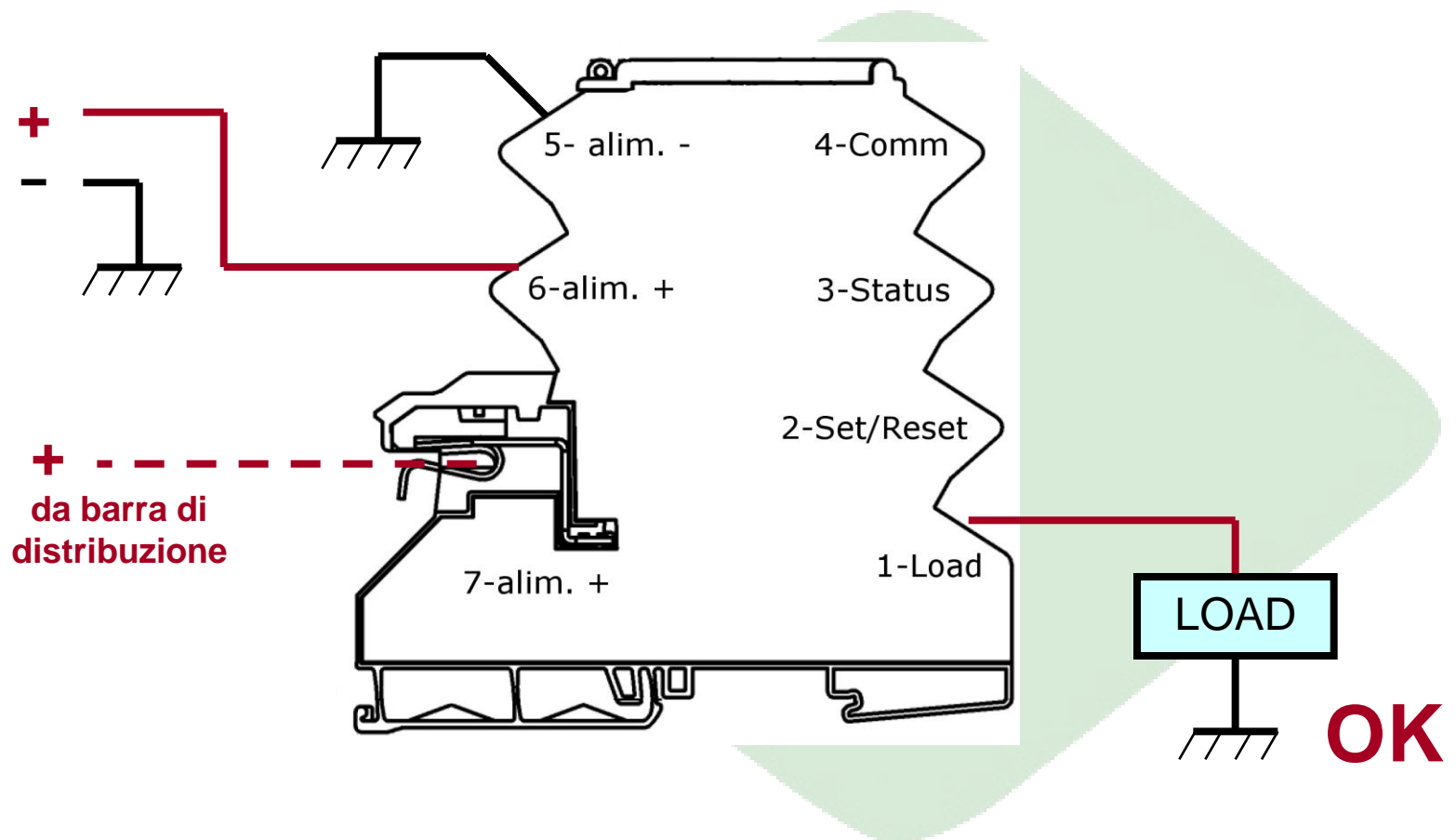

# Set/Reset

Set / Rest commands can be performed by the pushbutton on front pannel as well as by a PLC output

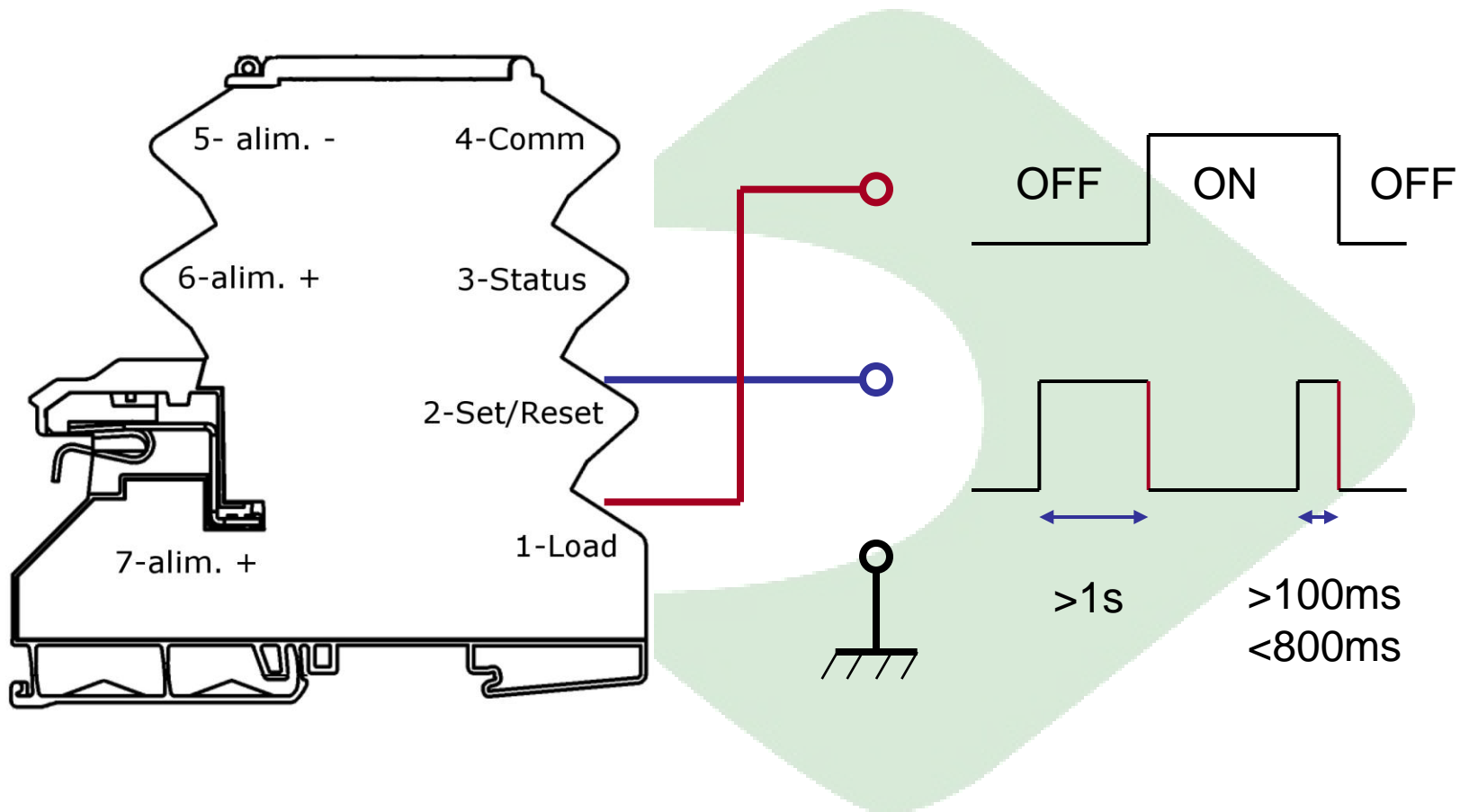

# Functions and versions

Functions	Description
Set /Reset	Digital signal 24 Vdc for on /off remote command of CEP-Dx OFF: 24 Vdc (pulse > 100ms and < 800ms, falling slope) ON : 24 Vdc (pulse > 1sec, falling slope)
Single or centralized failure signal	Digital output 24 Vdc for remote failure signal (see pic. 4 for connections) <b>CEP-D1</b> High status = OK Low status = load supply switched off for ovd or short cc <b>CEP-D2</b> High status = OK Low status = load supply switched off for ovd or short cc <b>CEP-D3</b> The behaviour is programable
One wire BUS	Available on CEP-D3 version

# Staus LED indicatison

Stauts indications	Function	Description
LED green	OK	Status OK, normal function.
LED red	OFF	Manual switched off.
LED green, blinking 1Hz	load at 90%	Current has reached 90% of selected current value
LED red, blinking 1Hz	overload	output switched off for overcurrent
LED red, blinking 5Hz	error	the module failed and must be replaced