



Maschinen- und Geräteschutzschalter F/FM-Reihe

Motor protective switches
for machines and equipments
F/FM series

General Information	Allgemeine Informationen	158
F/FM series	F/FM-Reihe	159 - 164
Dimensions	Maßzeichnungen	165 - 166



Allgemeine Erläuterungen General

Anwendung

Der Maschinen- und Geräteschutzschalter wurde entwickelt für den Einsatz bei Serienmaschinen bis zu einer Leistung von 4 kW in AC-3 bei 400 V. Durch die Kombinationsmöglichkeiten von thermischer und/oder Unterspannungsauslösung kann die passende Auswahl der Schutzfunktion in Zusammenhang mit den verschiedenen Bauformen angeboten werden.

Technik

Motorschutzschalter: Thermische Auslösung entsprechend EN 60947-4-1 ist bis zu einem Motornennstrom $I_e = 15 \text{ A}/230 \text{ V}$ und $I_e = 10 \text{ A}/400 \text{ V}$ möglich.

FM2: Schaltung 2polig mit 2phasigem Bimetallschutz.

FM: Schaltung 3polig mit ebenfalls 2phasigem Bimetallschutz. Die Eichung der Bimetalle erfolgt als Festeinstellung auf den Motornennstrom werksseitig, so daß eine nachträgliche Veränderung nicht mehr möglich ist.

Eine Veränderung der thermischen Auslösung mit Hilfe einer Einstellskala und einem vorgegebenen Bereich ist bei unseren EM/MN-Schaltern möglich.

Unterspannungsauslösung

Die Schalter mit Unterspannungsauslösung erfüllen die Forderung VDE 0113/EN 60204 zum Schutz gegen selbsttätigen Wiederanlauf nach Netzausfall und Spannungswiederkehr.

Schaltung 012: Spule liegt zwischen L1 und N (Standard 230 V/50 Hz)

Schaltung 014: Spule liegt zwischen L1 und L2 (Standard 400 V/50 Hz).

Anschluß

Um eine zeitsparende und kostengünstige Verdrahtung bei Seriengeräten zu erreichen, wurde als Anschlußtechnik der Flachsteck-Anschluß 6,3 DIN 46245 festgelegt. In der Ausführung als Hauptschalter (HS) sind die Anschlußstellen durch eine berührungssichere Abdeckung geschützt.

Freiauslösung

Über ein robustes Schaltschloß löst der Schalter auch bei blockiertem Griff aus und verhindert einen Wiederanlauf.

Schutzart

Die im Katalog angegebene Schutzart gilt für senkrechte Montagelage.

Application

The motor protective switches for machines and equipment have been developed for serial machines with a power up to 4 kW in AC-3 under 400 V. Different combinations with thermal protection and/or undervoltage release are possible depending on the application.

Technic

Motor protective switches: Thermal release following EN 60947-4-1 is possible for nominal current of motor up to $I_e = 15 \text{ A}/230 \text{ V}$ and $I_e = 10 \text{ A}/400 \text{ V}$.

FM2: Two pole switch with a protection through 2 bimetals.

FM: Three pole switch with also a protection through 2 bimetals. The bimetal rating is factory set, depending on the nominal current of the motor to protect. Modification of the setting point isn't possible any more.

Adjustment of the thermal release with a setting scale is possible on our switches type EM/MN.

Undervoltage release

The switches with undervoltage release are in accordance with VDE 0113/EN 60204 standard for the protection of people with "prohibiting" the automatic restarting of any machine after a power failure.

Sketch 012: The coil is connected between L1 and N (Standard 230 V/50 Hz)

Sketch 014: The coil is connected between L1 and L2 (Standard 400 V/50 Hz).

Connection

To save costs and time when wiring the switch, connection with 6,3 mm fast-on connectors according to DIN 46245 are used. When the switch terminals are protected through an envelopping terminal shroud.

Free release

Through a strong release mechanism, the switch is opened automatically and avoids any restarting – also possible although handle is blocked.

Kind of protection

Kind of protection mentioned in catalogue is for vertical mounting.

Hauptschalter = Not-Aus-Schalter
Main switches = Emergency-off switches

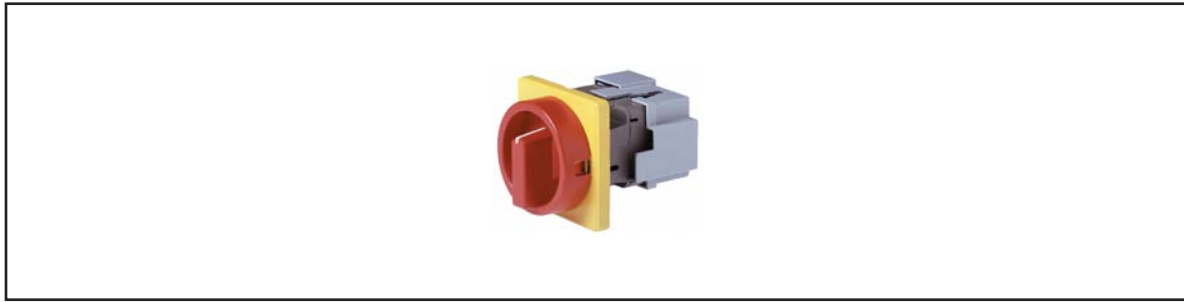

Thermische Auslösung
 Thermal release

IP 54	Hauptschalter – Not-Aus-Schalter 2polig Main switch – Emergency-off switch 2 poles	Frontbefestigung mit Dreischloßverriegelung Front fixing with interlocking for 3 padlocks F-D
	Typ Type	Best.-Nr. Ref. No.
	FM2/HS-F3-D-RG	je nach E.P. ¹⁾

Wechselstrom
 Alternating current

Thermische Auslösung
 Thermal release

IP 54	Hauptschalter – Not-Aus-Schalter 3polig, Bimetallschutz 2polig Main switch – Emergency-off switch triple poles, 2 pole bimetal protection	Frontbefestigung mit Dreischloßverriegelung Front fixing with interlocking for 3 padlocks F-D
	Typ Type	Best.-Nr. Ref. No.
	FM/HS-F3-D-RG	je nach E.P. ¹⁾

Drehstrom
 Three phase current

Thermische und Unterspannungsauslösung
 Thermal and undervoltage release

IP 54	Hauptschalter – Not-Aus-Schalter 2polig Main switch – Emergency-off switch 2 poles	Frontbefestigung mit Dreischloßverriegelung Front fixing with interlocking for 3 padlocks F-D
	Spulenspannung Coil voltage	Typ Type
	230 V, 50 Hz	Best.-Nr. Ref. No.
		FM2 02/HS-F3-D-RG
		je nach E.P. ¹⁾

Wechselstrom
 Alternating current

Thermische und Unterspannungsauslösung
 Thermal and undervoltage release

IP 54	Hauptschalter – Not-Aus-Schalter 3polig, Bimetallschutz 2polig Main switches – Emergency-off switches triple poles, 2 pole bimetal protection	Frontbefestigung mit Dreischloßverriegelung Front fixing with interlocking for 3 padlocks F-D
	Spulenspannung Coil voltage	Typ Type
	230 V, 50 Hz	Best.-Nr. Ref. No.
		FM 012/HS-F3-D-RG
		je nach E.P. ¹⁾
	400 V, 50 Hz	Best.-Nr. Ref. No.
		FM 014/HS-F3-D-RG
		je nach E.P. ¹⁾

Drehstrom
 Three phase current

¹⁾ E.P. Eichpunkt der Bimetalle. Bitte im Bestellfall angeben.
 Calibration point of bimetal. Please indicate when ordering.



Maschinen- und Geräteschutzschalter

Motor protective switches for machines and equipments



Thermische Auslösung
Thermal release

Wechselstrom Alternating current	IP 54	Ein-Aus-Schalter 2polig On-off switch 2 poles	isogekapselt in plastic enclosure T-B	
			Typ Type	Best.-Nr. Ref. No.
			FM2-T7/5-B-GSX	je nach E.P. ¹⁾

Thermische Auslösung
Thermal release

Drehstrom Three phase current	IP 54	Ein-Aus-Schalter 3polig, Bimetallschutz 2polig On-off switch triple poles, 2 pole bimetal protection	isogekapselt in plastic enclosure T-B	
			Typ Type	Best.-Nr. Ref. No.
			FM-T7/5-B-GSX	je nach E.P. ¹⁾

Thermische und Unterspannungsauslösung
Thermal and undervoltage release

Wechselstrom Alternating current	IP 54	Ein-Aus-Schalter 2polig On-off switch 2 poles	isogekapselt in plastic enclosure T-B	
		Spulenspannung Coil voltage	Typ Type	Best.-Nr. Ref. No.
		230 V, 50 Hz	FM2 02-T7/5-B-GSX	je nach E.P. ¹⁾

Thermische und Unterspannungsauslösung
Thermal and undervoltage release

Drehstrom Three phase current	IP 54	Ein-Aus-Schalter 3polig, Bimetallschutz 2polig On-off switches triple poles, 2 pole bimetal protection	isogekapselt in plastic enclosure T-B	
		Spulenspannung Coil voltage	Typ Type	Best.-Nr. Ref. No.
		230 V, 50 Hz	FM 012-T7/5-B-GSX	je nach E.P. ¹⁾
		400 V, 50 Hz	FM 014-T7/5-B-GSX	je nach E.P. ¹⁾

¹⁾ E.P. Eichpunkt der Bimetalle. Bitte im Bestellfall angeben.
Calibration point of bimetal. Please indicate when ordering.

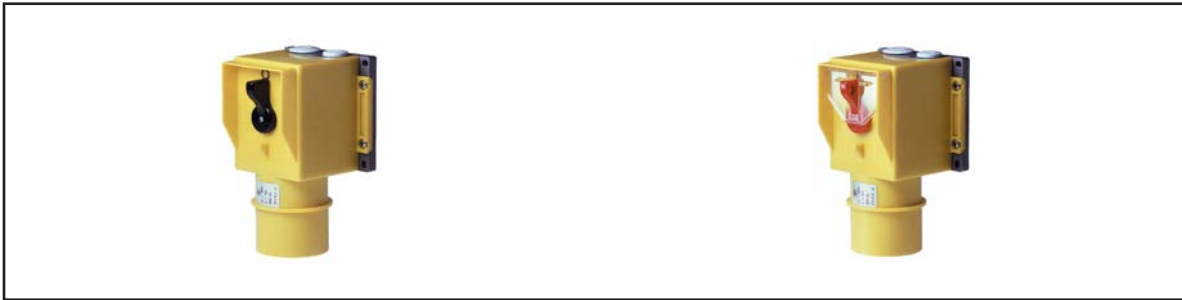

Thermische Auslösung
 Thermal release

Ein-Aus-Schalter 3polig, Bimetallschutz 2polig IP 53 On-off switch triple poles, 2 pole bimetal protection		isogekapselt mit CEE-Gerätestecker 5polig, 16 A, 400 V (3 P+N+⊕) in plastic enclosure with CEE plug 5 poles, 16 A, 400 V CT-S
	Typ Type	Best.-Nr. Ref. No.
	CGFM 516/6h-CT7/6-S-GSX	je nach E.P. ¹⁾

Drehstrom
 Three phase current

Thermische und Unterspannungsauslösung
 Thermal and undervoltage release

Ein-Aus-Schalter 3polig, Bimetallschutz 2polig IP 53 On-off switches triple poles, 2 pole bimetal protection		isogekapselt mit CEE-Gerätestecker 5polig, 16 A, 400 V (3 P+N+⊕) in plastic enclosure with CEE plug 5 poles, 16 A, 400 V CT-S
Spulenspannung Coil voltage	Typ Type	Best.-Nr. Ref. No.
230 V, 50 Hz	CGFM 012 516/6h-CT7/6-S-GSX	je nach E.P. ¹⁾
400 V, 50 Hz	CGFM 014 516/6h-CT7/6-S-GSX	je nach E.P. ¹⁾

Drehstrom
 Three phase current

Thermische Auslösung
 Thermal release

IP 53 Hauptschalter – Not-Aus-Schalter 3polig, Bimetallschutz 2polig Main switch – Emergency-off switch triple poles, 2 pole bimetal protection		isogekapselt mit Einschloßverriegelung und CEE-Gerätestecker 5polig, 16 A, 400 V (3 P+N+⊕) in plastic enclosure with interlocking for 1 padlock and CEE plug 5 poles, 16 A, 400 V CT-SE
	Typ Type	Best.-Nr. Ref. No.
	CGFM/HS 516/6h-CT7/6-SE-GRX	je nach E.P. ¹⁾

Drehstrom
 Three phase current

Thermische und Unterspannungsauslösung
 Thermal and undervoltage release

IP 53 Hauptschalter – Not-Aus-Schalter 3polig, Bimetallschutz 2polig Main switch – Emergency-off switch triple poles, 2 pole bimetal protection		isogekapselt mit Einschloßverriegelung und CEE-Gerätestecker 5polig, 16 A, 400 V (3 P+N+⊕) in plastic enclosure with interlocking for 1 padlock and CEE plug 5 poles, 16 A, 400 V CT-SE
Spulenspannung Coil voltage	Typ Type	Best.-Nr. Ref. No.
230 V, 50 Hz	CGFM 012/HS 516/6h-CT7/6-SE-GRX	je nach E.P. ¹⁾
400 V, 50 Hz	CGFM 014/HS 516/6h-CT7/6-SE-GRX	je nach E.P. ¹⁾

Drehstrom
 Three phase current

¹⁾ E.P. Eichpunkt der Bimetalle. Bitte im Bestellfall angeben. Calibration point of bimetals. Please indicate when ordering.



Maschinen- und Geräteschutzschalter

Motor protective switches for machines and equipments



Thermische Auslösung
Thermal release

Wechselstrom Alternating current	IP 53	Ein-Aus-Schalter 2polig On-off switch 2 poles	isogekapselt mit CEE-Gerätestecker 3polig, 16 A, 230 V (2 P + ⊕) in plastic enclosure with CEE plug 3 poles, 16 A, 230 V CT-S
			Typ Type
			Best.-Nr. Ref. No.
		CGFM2 316/6h-CT7/6-S-GSX	je nach E.P. ¹⁾

Thermische und Unterspannungsauslösung
Thermal and undervoltage release

Wechselstrom Alternating current	IP 53	Ein-Aus-Schalter 2polig On-off switch 2 poles	isogekapselt mit CEE-Gerätestecker 3polig, 16 A, 230 V (2 P + ⊕) in plastic enclosure with CEE plug 3 poles, 16 A, 230 V CT-S
		Spulenspannung Coil voltage	Typ Type
		230 V, 50 Hz	Best.-Nr. Ref. No.
		CGFM2 02 316/6h-CT7/6-S-GSX	je nach E.P. ¹⁾

Thermische Auslösung
Thermal release

Wechselstrom Alternating current	IP 53	Ein-Aus-Schalter 2polig On-off switch 2 poles	isogekapselt mit Schutzkontakt-Gerätestecker 16 A, 230 V (2 P + ⊕) in plastic enclosure with earth contact plug 16 A, 230 V ST-S
			Typ Type
			Best.-Nr. Ref. No.
		SGFM2-ST7/6-S-GSX	je nach E.P. ¹⁾

Thermische und Unterspannungsauslösung
Thermal and undervoltage release

Wechselstrom Alternating current	IP 53	Ein-Aus-Schalter 2polig On-off switch 2 poles	isogekapselt mit Schutzkontakt-Gerätestecker 16 A, 230 V (2 P + ⊕) in plastic enclosure with earth contact plug 16 A, 230 V ST-S
		Spulenspannung Coil voltage	Typ Type
		230 V, 50 Hz	Best.-Nr. Ref. No.
		SGFM2 02-ST7/6-S-GSX	je nach E.P. ¹⁾

Maßzeichnungen Seite 166
Dimensions page 166

¹⁾ E.P. Eichpunkt der Bimetalle. Bitte im Bestellfall angeben. Calibration point of bimetal. Please indicate when ordering.



Weitere Varianten
Further variants

Ausführung Execution	Kurzbezeichnung Identification
-------------------------	-----------------------------------

Bauformen Types

 <p>* IP 54 frontseitig frontal</p>	<p>Frontbefestigung mit Abdeckhaube Haube mit Würgenippel zur Kabeleinführung. Front fixing under plastic cover Plastic cover with cable entries for dust protection.</p>	<p>HF3</p>
 <p>IP 54 frontseitig frontal</p>	<p>Isogekapselt mit Vorhängeschloß-Verriegelung für 1 Schloß In plastic enclosure with interlocking device for 1 padlock</p>	<p>SE</p>
 <p>IP 44</p>	<p>Isogekapselt mit CEE-Gerätestecker 516/6h und Phasenwender zur Drehrichtungsumkehr In plastic enclosure with CEE-plug 516/6h and phase inverter for changing of rotary sense.</p>	<p>516 P/6h</p>

Sonderbauformen Special types

 <p>IP 54</p>	<p>Frontbefestigung – Schaltereinsatz gekapselt Schaltereinsatz gekapselt für Schutzart IP 54. Bei offenen Maschinenräumen bietet das Kunststoffgehäuse Schutz vor dem Eindringen von Staub und Wasser. Schutzart frontseitig IP 65, hinter der Maschinenwand IP 54. Front fixing – Enclosed switch insert. Enclosed switch insert – degree of protection IP 54. The plastic enclosure avoids penetration of dust and water in case of open machine rooms. Degree of protection frontside IP 65, behind machine wall IP 54.</p>	<p>HT</p>
--	--	-----------

* Schutzart der Frontplatten IP 65 gegen Mehrpreis lieferbar.
 Kind of protection IP 65 of the front plates available at extra charge.



Technische Daten nach IEC/EN 60947
Technical data as per IEC/EN 60947

	FM	F	Strom-Zeit-Kennlinie FM-Reihe Characteristic curve of tripping time and rated current serie FM															
Bemessungsisolationsspannung III/3 Rated insulating voltage III/3	U_i V	440	440	Kalter Zustand (Mittelwert) Cold condition (average value)														
Bemessungsstoßspannungsfestigkeit III/3 Rated impulse voltage rigidity III/3	U_i kV	4	4															
Bemessungsdauerstrom Rated uninterrupted current	I_u offen I_{the} gekapselt open the enclosed	15	16															
Anschließbare Querschnitte feindrätig Steckhülse 6,3 – 2,5 DIN 46245 Connectable cross sections fine wire Plug-in bush 6,3 – 2,5 DIN 46245	mm ²	1 – 2,5	1 – 2,5															
Hauptschaltereigenschaften nach IEC/EN 60204 Properties of main switches as per IEC/EN 60204				<p>Die Auslösekennlinie zeigt den Öffnungsverzögerung der Schalter als Mittelwerte der Streubänder aus dem kalten Zustand bei 20 °C Umgebungstemperatur. Bei betriebswarmen Geräten sinkt die Auslösezeit der Bimetallauslöser auf ca. 1/4 der abgelesenen Werte.</p> <p>The tripping curve shows the delay in the opening of the switches as average values of tripping times from cold condition and an ambient temperature of 20 °C. With service warm switches, the responding time of the bimetal trips sinks to about 1/4 of the values taken out of the diagram.</p>														
Trennerbedingungen erfüllt bis Requirements for isolators complied with up to	V~	≤ 440	≤ 440															
Schaltvermögen bei Wechselfspannung Switching capacity under alternating voltage conditions				Eichpunkte (E.P.) und Versicherungen Calibration points (C.P.) and back-up fuses														
AC-21A/B Lastschalter Load break switches																		
Bemessungsbetriebsspannung Rated operating voltage	U_e V~	440	440	<table border="1"> <thead> <tr> <th>Eichpunkt (E.P.) Calibration point (C.P.)</th> <th>Max. Versicherung mit thermischer Auslösung Maximum back-up fuses with thermal release gL A</th> </tr> </thead> <tbody> <tr> <td>A</td> <td></td> </tr> <tr> <td>≤ 1,2</td> <td>2</td> </tr> <tr> <td>> 1,2 ≤ 1,7</td> <td>4</td> </tr> <tr> <td>> 1,7 ≤ 2,6</td> <td>6</td> </tr> <tr> <td>> 2,6 ≤ 4,0</td> <td>10</td> </tr> <tr> <td>> 4,0 ≤ 15,0</td> <td>16</td> </tr> </tbody> </table>	Eichpunkt (E.P.) Calibration point (C.P.)	Max. Versicherung mit thermischer Auslösung Maximum back-up fuses with thermal release gL A	A		≤ 1,2	2	> 1,2 ≤ 1,7	4	> 1,7 ≤ 2,6	6	> 2,6 ≤ 4,0	10	> 4,0 ≤ 15,0	16
Eichpunkt (E.P.) Calibration point (C.P.)	Max. Versicherung mit thermischer Auslösung Maximum back-up fuses with thermal release gL A																	
A																		
≤ 1,2	2																	
> 1,2 ≤ 1,7	4																	
> 1,7 ≤ 2,6	6																	
> 2,6 ≤ 4,0	10																	
> 4,0 ≤ 15,0	16																	
Bemessungsbetriebsstrom Rated operating current	I_e A	–	16															
AC-23A/B Motorschalter (Hauptschalter) Motor switches (Main switches)																		
Bemessungsbetriebsstrom bzw. Motorleistung Rated operating current resp. motor rating																		
I_e in AC-3/AC-23A/B	230 V, 1~ 220...240 V, 3~ 380...440 V, 3~	15 A 15 A 10 A	2,2 kW 4,0 kW 4,0 kW															

Maßzeichnungen
 Dimensions

Frontbefestigung F
 Front fixing F

Maße in mm
 Dimensions in mm

Fronteinheit
 Front unit

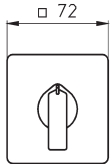

Schaltereinsatz
 Insert

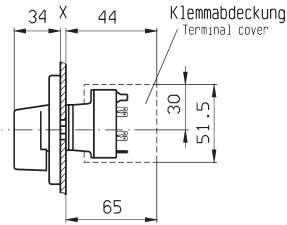

Schalterstirnseite
 Front view

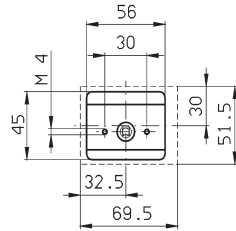

Bohrbild in der Befestigungswand
 Panel drilling

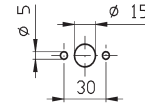

Frontbefestigung mit Unterspannungsauslösung F
 Front fixing with undervoltage release F

Fronteinheit
 Front unit

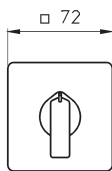

Schaltereinsatz
 Insert

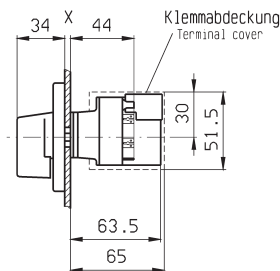

Schalterstirnseite
 Front view

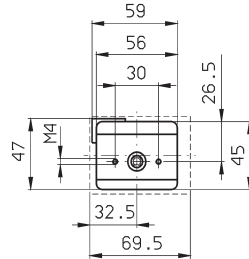

Bohrbild in der Befestigungswand
 Panel drilling

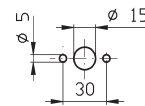

Frontbefestigung mit Haube HF
 Front fixing with cover HF

Fronteinheit
 Front unit

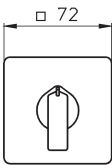

Schaltereinsatz
 Insert

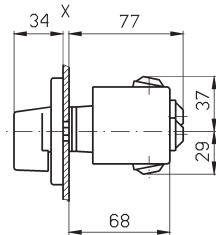

Schalterstirnseite
 Front view

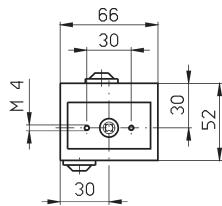

Bohrbild in der Befestigungswand
 Panel drilling

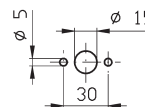

Frontbefestigung hinter der Montagewand HT
 Front fixing behind mounting plate HT

Fronteinheit
 Front unit

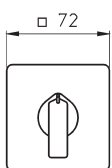

Schaltereinsatz
 Insert

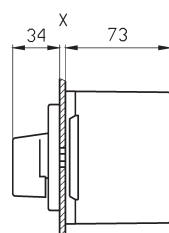

Schalterstirnseite
 Front view

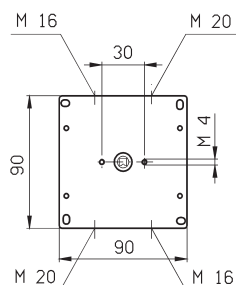

Bohrbild in der Befestigungswand
 Panel drilling

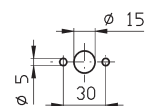

Maß Dimension X max. 2

Maßzeichnungen
Dimensions

isogekapselt T
in plastic enclosure T

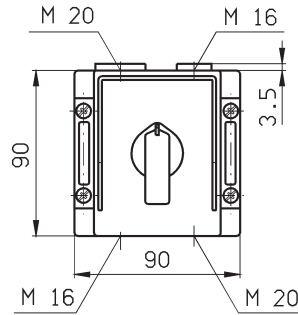
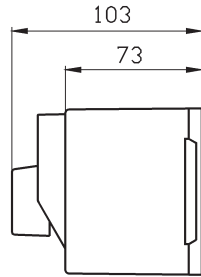

Bohrbild in der Befestigungswand
 Panel drilling

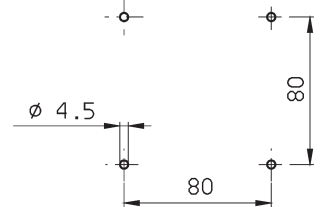

isogekapselt mit Schutzkontakt-Gerätestecker ST
in plastic enclosure with earth contact plug ST

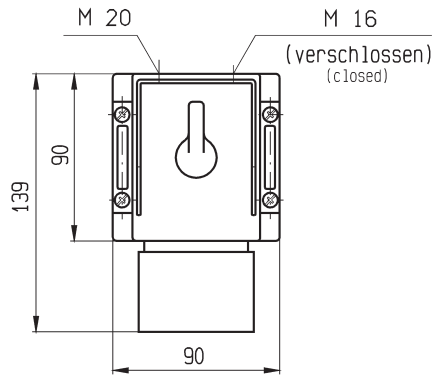
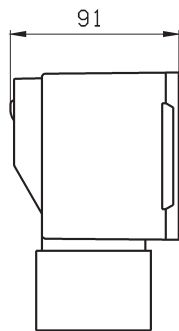

Bohrbild in der Befestigungswand
 Panel drilling

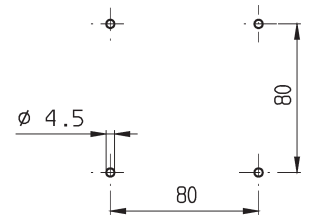

isogekapselt mit CEE-Gerätestecker CT/CT-SE
in plastic enclosure with CEE plug CT/CT-SE

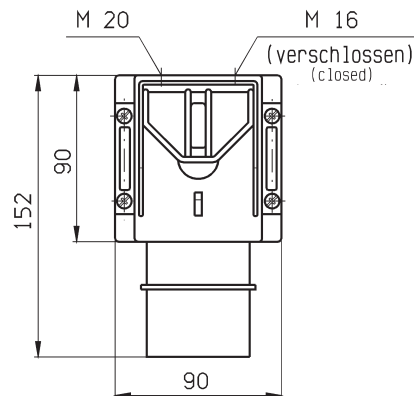
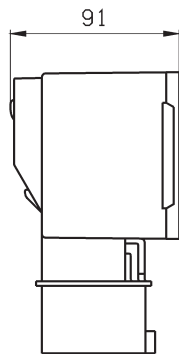

Bohrbild in der Befestigungswand
 Panel drilling

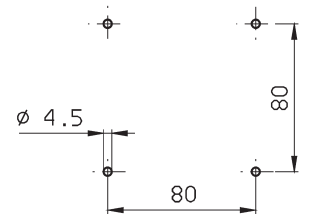

Maße in mm
 Dimensions in mm