

PC SOLUTIONS



- Enclosures with PC front panels with innovative design
- PC enclosures with sliding shelf
- Workplaces for industrial PCs



CHARACTERISTICS/DELIVERY

- ARETA structure with rear door or panel
- complete PC front panel ATPC (see specification on next page)
- monitor support
- CPU support

PAINT FINISH

- ETA standard epoxy polyester powder coating.
- structure: colour RAL 7035 smooth finish
 - door or rear panel: colour RAL 7035 textured finish.
 - roof, floor and PC front panel: RAL 7025 textured finish.
 - front panels and tilting shelf, aluminum grey with textured finish

PROTECTION RATINGS

- IP 55.

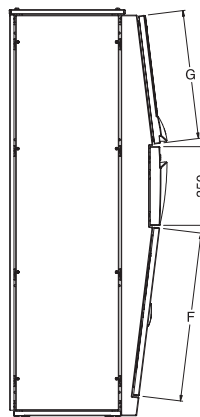
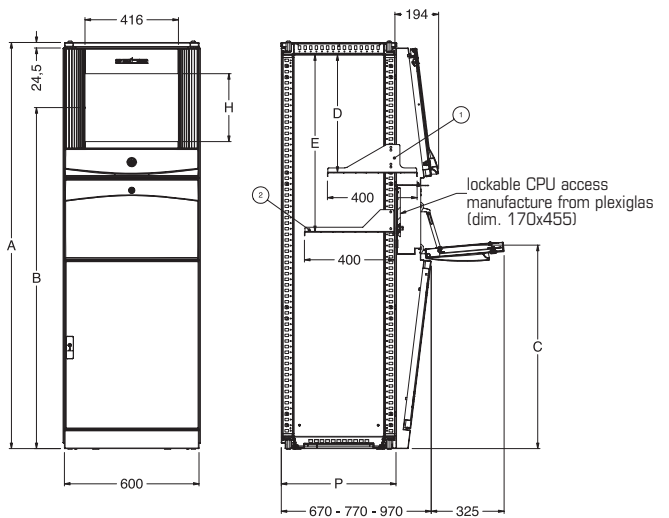

MAIN ACCESSORIES



ATFI side panels (see page 44)



plinth for Areta pc (see page 131)



(1) WTM0000600 monitor support



(2) WTPU000600 CPU support (see page 128)

DIMENSIONAL SPECIFICATIONS

DIMENSIONS			CABINET DIMENSIONS			FURTHER DIMENSIONS					
WIDTH	HEIGHT	DEPTH	WIDTH	HEIGHT	DEPTH	B	C	D	E	F	G
600	1600	500	600	1609	514	1370	790	424	688	653	475
600	1600	600	600	1609	614	1370	790	424	688	653	475
600	1600	800	600	1609	814	1370	790	424	688	653	475
600	1800	500	600	1809	514	1520	890	524	788	753	575
600	1800	600	600	1809	614	1520	890	524	788	753	575
600	1800	800	600	1809	814	1520	890	524	788	753	575
600	2000	500	600	2009	514	1580	890	724	988	753	775
600	2000	600	600	2009	614	1580	890	724	988	753	775
600	2000	800	600	2009	814	1580	890	724	988	753	775

CODES FOR ASSEMBLED ARETA PC

CABINET DIM.			CABINET WITH REAR DOOR*	CABINET WITH REAR PANEL*
L	A	P		
600	1600	500	ATPC061605FP	ATPC061605FR
600	1600	600	ATPC061606FP	ATPC061606FR
600	1600	800	ATPC061608FP	ATPC061608FR
600	1800	500	ATPC061805FP	ATPC061805FR
600	1800	600	ATPC061806FP	ATPC061806FR
600	1800	800	ATPC061808FP	ATPC061808FR
600	2000	500	ATPC062005FP	ATPC062005FR
600	2000	600	ATPC062006FP	ATPC062006FR
600	2000	800	ATPC062008FP	ATPC062008FR

* The monitor support WTMO and the CPU support WTPU are included in the supply.

CODES FOR FLAT-PACK ARETA PC

DIMENSIONS			TOP + BOTTOM	** FRONT STRUCTURE ATPC + FRONTAL UPRIGHTS	DOORS + REAR UPRIGHTS	REAR PANEL + REAR UPRIGHTS
L	A	P				
600	1600	500	ATTF060050	ATPC060160	ATP0060160	ATRE060160
600	1600	600	ATTF060060	ATPC060160	ATP0060160	ATRE060160
600	1600	800	ATTF060080	ATPC060160	ATP0060160	ATRE060160
600	1800	500	ATTF060050	ATPC060180	ATP0060180	ATRE060180
600	1800	600	ATTF060060	ATPC060180	ATP0060180	ATRE060180
600	1800	800	ATTF060080	ATPC060180	ATP0060180	ATRE060180
600	2000	500	ATTF060050	ATPC060200	ATP0060200	ATRE060200
600	2000	600	ATTF060060	ATPC060200	ATP0060200	ATRE060200
600	2000	800	ATTF060080	ATPC060200	ATP0060200	ATRE060200

Complete internal fitting with the monitor support WTMO and the CPU support WTPU.

** PC FRONT STRUCTURE ATPC

CHARACTERISTICS/DELIVERY

The PC front panel includes:

- frame made of 15/10 thick sheet steel
- silk-screen printed clear door for monitor vision, made of sheet steel with thermoplastic coating
- tilting shelf to fix the keyboard, made of 15/10 thick sheet steel
- lower door made of 20/10 thick sheet steel
- clear Plexiglas door with seal to protect and access the CPU
- cable gland for keyboard and mouse cables
- bi-adhesive tape for keyboard installation
- seal and mounting accessories
- pair of structural uprights

PAINT FINISH

Frame: RAL 7025 textured finish.

Front panels and tilting shelf: dark grey textured finish.

For painting different from RAL 7035 textured finish, rear panels and tilting shelf will remain dark grey textured finish.

KEYBOARD MAX. DIM.

VERSION	WIDTH	HEIGHT	DEPTH
STANDARD	500	80	255
WITH MOUSE SHELF	500	55	240

ARETA PC ENCLOSURE WITH SLIDING SHELF



MAIN ACCESSORIES



ATFI side panels (see page 44)



eyebolts (see page 46)



lifting brackets (see page 46)



plinth for Areta pc (see page 131)

CHARACTERISTICS/DELIVERY

The enclosure mounting kit includes:

- structure of 15/10 thick sheet steel with rear door and lower blank front hatch

The front section has to be completed with:

- clear upper door for monitor vision (alternatively, upper screwed blank panel or upper hinged blank door)
- extractable shelf with tilting front including removable mouse pad (alternatively, blank panel)
- tight container to separate keyboard compartment/enclosure, complete with: cable gland for keyboard and mouse, bi-adhesive tape for keyboard installation, monitor support.

PAINT FINISH

ETA standard epoxy polyester powder coating.

- structure: colour RAL 7035 smooth finish
- PC front and rear door: colour RAL 7035 textured finish
- roof and bottom: colour RAL 7025 textured finish
- profiles for the fixing of the transparent panel: colour RAL 7025

PROTECTION RATINGS

- IP 55.

DIMENSIONAL SPECIFICATIONS

DIMENSIONS			FURTHER DIM.			
WIDTH	HEIGHT	DEPTH	A	B	H	P
600	1800	600	1809	1420	530	614
600	1800	800	1809	1420	530	814
600	2000	600	2009	1520	730	614
600	2000	800	2009	1520	730	814

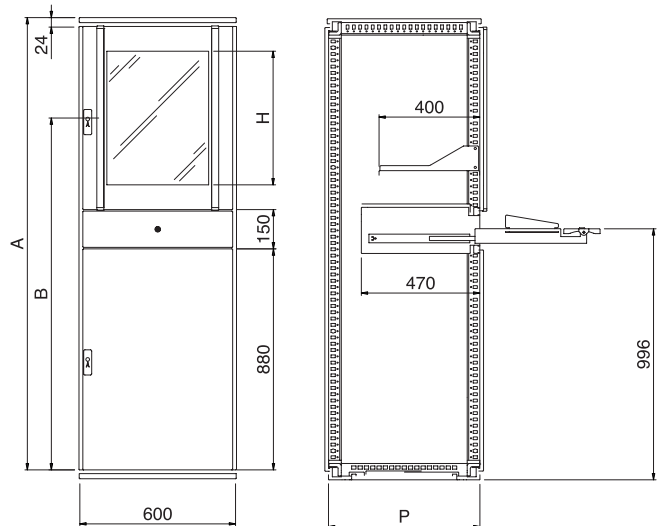

CODES OF ARETA PC WITH SLIDING SHELF

CABINET DIMENSIONS			STRUCTURE WITH LOWER BLANK HATCH (A)	CLEAR UPPER DOOR* (B)	SLIDING SHELF** (C)	MONITOR SUPPORT (D)
WIDTH	HEIGHT	DEPTH				
600	1800	600	ATPC061806CEC	ATPC180PX	ATPC001CE	WTPU000600
600	1800	800	ATPC061808CEC	ATPC180PX	ATPC001CE	WTPU000600
600	2000	600	ATPC062006CEC	ATPC200PX	ATPC001CE	WTPU000600
600	2000	800	ATPC062008CEC	ATPC200PX	ATPC001CE	WTPU000600

* Alternatively, the upper screwed blank panel ATPC ... PN or the upper hinged blank door ATPC ... PC can be installed.
 ** Alternatively, the blank panel ATPC015PN can be installed.

STRUCTURE WITH LOWER BLANK HATCH ATPC ... CEC (A)

CHARACTERISTICS/DELIVERY

The PC front enclosure with sliding shelf includes the following items:

- structure with rear door
- lower door made of 20/10 thick sheet steel
- rear door made of 20/10 sheet steel

Complete the front with the relevant accessories, sliding shelf and monitor support.

PAINT FINISH

- structure: colour RAL 7035 smooth finish
- roof and bottom: colour RAL 7025 textured finish
- doors: colour RAL 7035 textured finish.

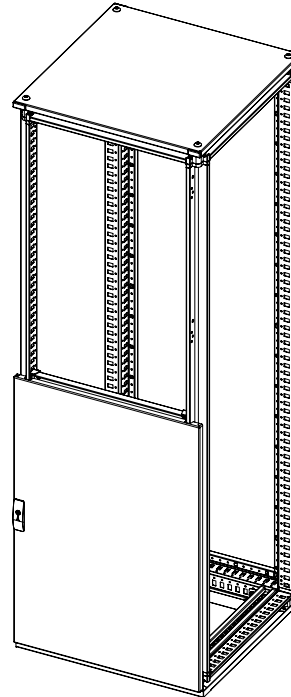

CLEAR UPPER DOOR ATPC ... PX (B)

CHARACTERISTICS

Manufactured from 20/10 sheet steel with plexiglas.

DELIVERY

Hatch with internal mounting profile, hinges and accessories.

PAINT FINISH

Colour: RAL 7035 textured finish.

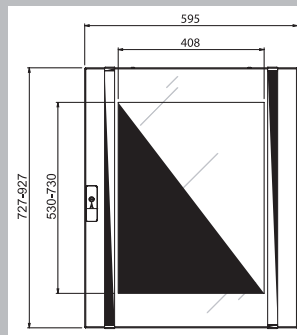

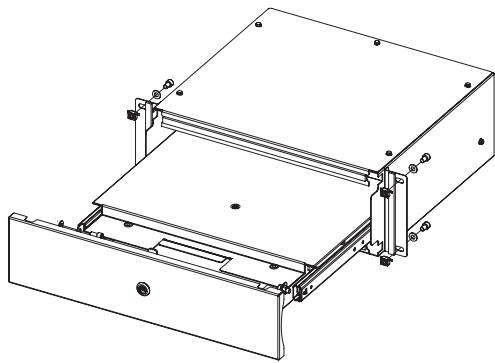

SLIDING SHELF ATPC001CE (C)

CHARACTERISTICS

Manufactured from 15/10 sheet steel.

PAINT FINISH

Colour: RAL 7035 textured finish.

DELIVERY

Sliding shelf with tilting front, complete with extractable mouse pad and double bar central closure.

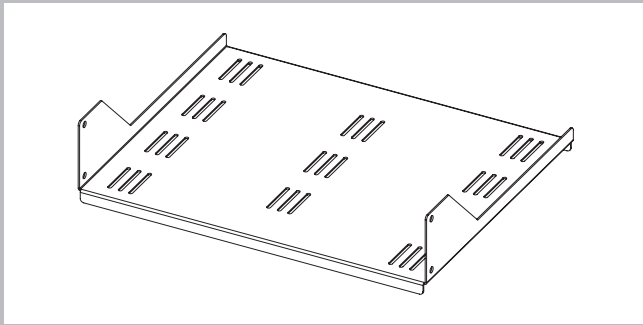

MONITOR SUPPORT WTPU000600 (D)

Manufactured from 15/10 sheet steel.

PAINT FINISH

Colour: RAL 7035 textured finish.

DELIVERY

Support complete with mounting hardware.

ALTERNATIVE ACCESSORIES ARETA PC ENCLOSURE WITH SLIDING SHELF

UPPER SCREWED BLANK PANEL ATPC ... PN (ALTERNATIVE TO ATPC ... PX)

CHARACTERISTICS

Manufactured from 15/10 sheet steel.

PAINT FINISH

Colour: RAL 7035 textured finish.

DELIVERY

Panel complete with internal mounting profile and hardware.

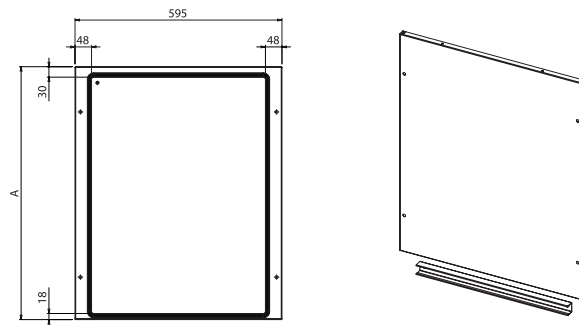

UPPER SCREWED BLANK PANEL

CODE ATPC	CABINET HEIGHT	A
ATPC180PN	1800	727
ATPC200PN	2000	927

UPPER HINGED BLANK PANEL

CODE ATPC	CABINET HEIGHT	A
ATPC180PC	1800	727
ATPC200PC	2000	927

UPPER HINGED BLANK PANEL ATPC ... PC (ALTERNATIVE TO ATPC ... PX)

CHARACTERISTICS

Manufactured from 20/10 sheet steel.

PAINT FINISH

Colour: RAL 7035 textured finish.

DELIVERY

Hatch with internal mounting profile, hinges and hardware.

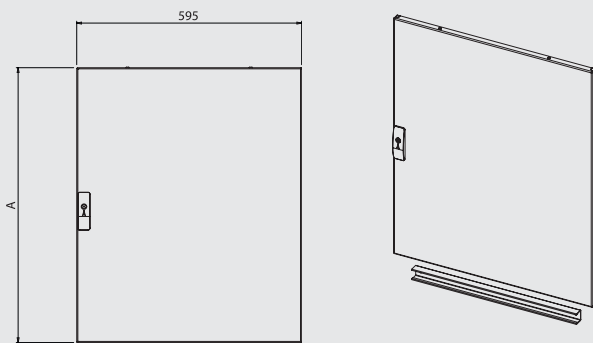

BLANK PANEL ATPC015PN (ALTERNATIVE TO ATPC001CE)

CHARACTERISTICS

Manufactured from 15/10 sheet steel.

PAINT FINISH

Colour: RAL 7035 textured finish.

DELIVERY

Blank panel with mounting screws.

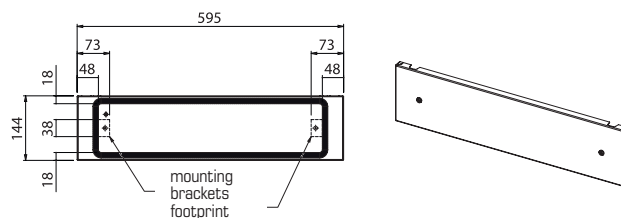



SLIDING SHELF WTRS

Manufactured from 15/10 sheet steel.
Maximum capacity 30kgs.

SLIDING SHELF		
WTRS CODE	DESCRIPTION	DELIVERY
WTRS000600	SLIDING SHELF (MAX CAPACITY 30 KGS)*	ONE PIECE WITH SLIDING RAILS

*To be ordered separately:
- WTPR mounting rails.

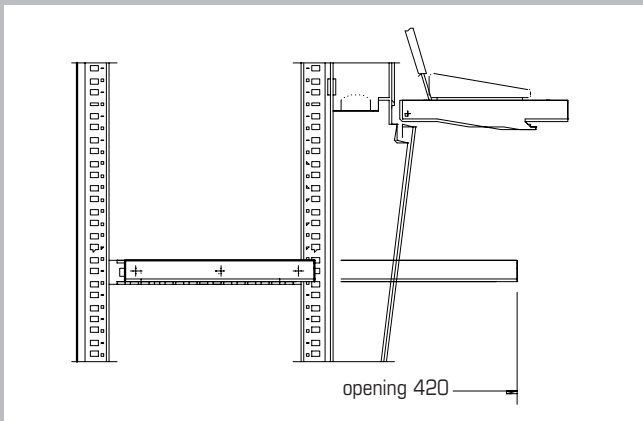

MOUNTING RAILS FOR WTRS			
WTPR CODE	DESCRIPTION	DELIVERY	CABINET DEPTH
WTPR-050040CP	MOUNTING RAILS	2 PIECES	400
WTPR-050050CP	MOUNTING RAILS	2 PIECES	500
WTPR-050060CP	MOUNTING RAILS	2 PIECES	600
WTPR-050080CP	MOUNTING RAILS	2 PIECES	800

FIXED SHELF WTRP

Manufactured from 20/10 sheet steel.

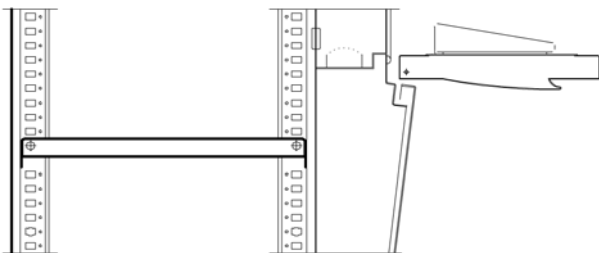

FIXED SHELF

WTRP CODE	DESCRIPTION	CABINET DEPTH	DELIVERY
WTRP060050	SHELF	514	ONE PIECE WITH MOUNTING ACCESSORIES
WTRP060060	SHELF	614	ONE PIECE WITH MOUNTING ACCESSORIES
WTRP060080	SHELF	814	ONE PIECE WITH MOUNTING ACCESSORIES

KEYBOARD SHELF WITH MOUSE PAD WTMS

Keyboard shelf manufactured from 15/10 sheet steel with lateral sliding mouse pad.

KEYBOARD SHELF WITH MOUSE PAD

WTMS CODE	DESCRIPTION	DELIVERY
WTMS001	KEYBOARD SHELF WITH LATERAL MOUSE PAD	ONE PIECE WITH MOUNTING ACCESSORIES

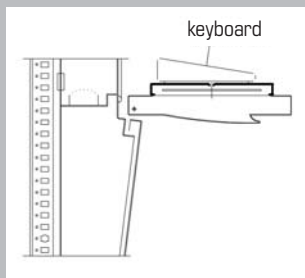

MAXIMUM KEYBOARD DIMENSION

WIDTH	HEIGHT	DEPTH
500	55	240



PLINTH

ATZP CODE	DESCRIPTION	CABINET DEPTH	A	DELIVERY	
ATZP-060050	PLINTH H=100	514	548	ONE PIECE WITH MOUNTING ACCESSORIES	FOR CABINET PC H=1800/2000
ATZP-060060	PLINTH H=100	614	648	ONE PIECE WITH MOUNTING ACCESSORIES	FOR CABINET PC H=1800/2000
ATZP-060080	PLINTH H=100	814	848	ONE PIECE WITH MOUNTING ACCESSORIES	FOR CABINET PC H=1800/2000
ATZP-060050S	PLINTH H=100	514	561	ONE PIECE WITH MOUNTING ACCESSORIES	FOR CABINET PC H=1600
ATZP-060060S	PLINTH H=100	614	661	ONE PIECE WITH MOUNTING ACCESSORIES	FOR CABINET PC H=1600
ATZP-060080S	PLINTH H=100	814	861	ONE PIECE WITH MOUNTING ACCESSORIES	FOR CABINET PC H=1600

Colour: RAL 7025 textured finish.

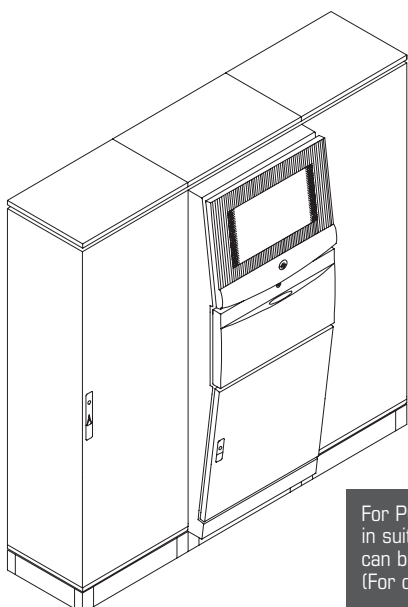

For PC cabinet mounted in suite a standard plinth can be used, if necessary. (For codes see page 217).

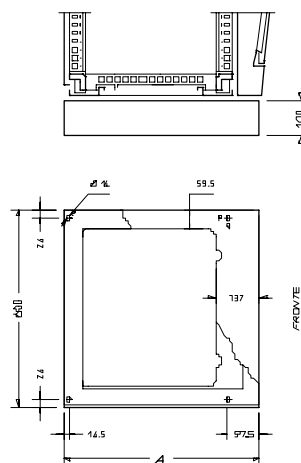

ARETA PC PLINTH holes for floor fixing



WHEEL WTRU-001

High quality polyamide wheel. Load capacity 80 kgs for each wheel. Supply includes 4 pieces, (2 wheels with brake, 2 rotating wheels).



PCCO ENCLOSURE FOR MONITOR AND CPU

It can incorporate a PC including central unit, monitor and keyboard. As an option, it can be provided with a sliding shelf to use the mouse. The monitor is protected by a transparent silk-screen printed panel made of sheet steel with thermoplastic coating. A transparent door fully protects the CPU from external agents also with lowered tilting cover.

CHARACTERISTICS/DELIVERY

- Manufactured from 15/10 pressbent sheet steel.
- removable rear cover made of 15/10 sheet steel
- silk-screen printed clear door for monitor vision, made of sheet steel with thermoplastic coating
- tilting shelf to fix the keyboard, made of 15/10 thick sheet steel
- adjustable monitor support made of 20/10 sheet steel
- CPU support made of 20/10 sheet steel
- clear door to protect and access the CPU
- cable gland for keyboard and mouse cables
- bi-adhesive tape for keyboard installation
- supporting column PCSU
- supporting base PCBA with levelling feet

PAINT FINISH

ETA standard epoxy polyester powder coating.
 Colour: RAL 7035 textured finish.
 Door and sliding shelf: aluminium grey textured finish.

PROTECTION RATINGS

IP 55.

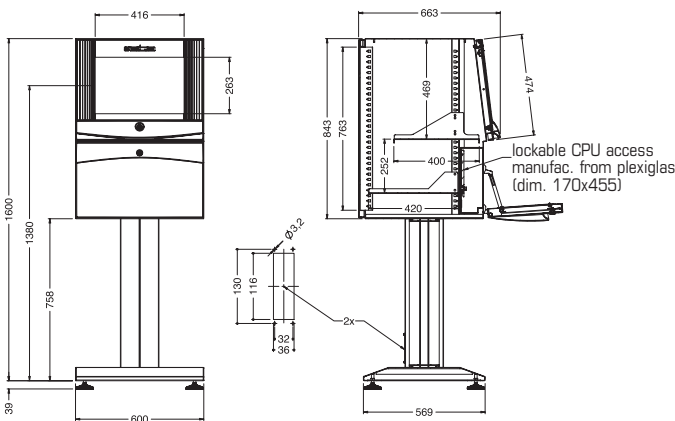

ENCLOSURE PCCO

PC CODE	DESCRIPTION
PCC0610	PC ENCLOSURE
PCSU800	SUPPORT
PCBA600	BASE WITH LEVELLING FEET

MOUSE SHELF ACCESSORY

Keyboard support manufactured from 15/10 sheet steel with lateral extractable mouse shelf. Supply includes nr. 1 piece with mounting accessories.

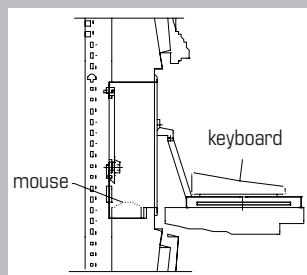

MOUSE ACCESSORY

WTMS CODE	DESCRIPTION
WTMS001	KEYBOARD SHELF FOR MOUSE



ENCLOSURE PCIN FOR MONITOR

Sliding drawer with mouse pad, accessible through tilting door that, once closed, offers IP protection for the enclosure.

CHARACTERISTICS/DELIVERY

- structure of 15/10 sheet steel
- removable rear cover made of 15/10 sheet steel
- silk-screen printed clear door for monitor vision, made of sheet steel with thermoplastic coating
- adjustable monitor support made of 20/10 sheet steel
- 15/10 sheet steel drawer, including: pair of telescopic guides, sliding shelf for mouse, front tilting door with closure, mounting hardware
- supporting column PCSU
- supporting base PCBA with levelling feet

PAINT FINISH

ETA standard epoxy polyester powder coating.
Colour: RAL 7035 textured finish.

Front panel and console: aluminium grey textured finish.

- for painting different from RAL 7035 textured finish, front panels and console will remain aluminium grey textured finish.

PROTECTION RATINGS

IP 55.

ENCLOSURE PCIN

PC CODE	DESCRIPTION
PCIN608	PC ENCLOSURE + KEYBOARD DRAWER WITH MOUSE SHELF AND TILTING DOOR
PCSU900	SUPPORT
PCBA600	BASE WITH LEVELLING FEET

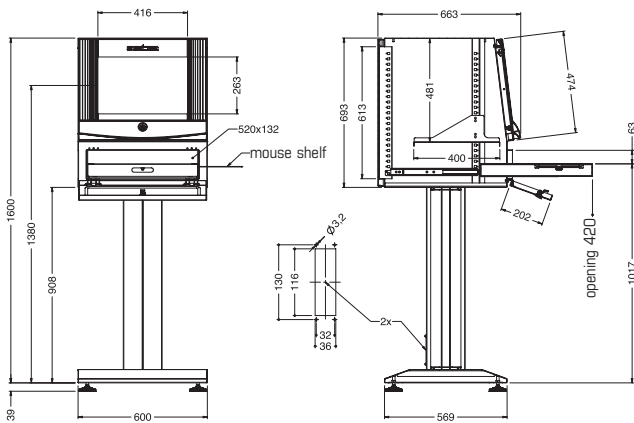

ACCESSORIES FOR PC HOUSING

WHEELS

WTRU CODE	DESCRIPTION	NR. OF PIECES
WTRU-001	WHEELS	4

