

FILTER FAN

FF 018 | 200m³/h



- > Low maintenance
- > Time-saving installation
- > High through-flow air volume
- > UV resistant
- > Functional design

Filter fans are used to provide an optimum climate in enclosures. The interior temperature of an enclosure can be reduced by channelling cooler filtered outside air into the enclosure thus expelling heated internal air. The resulting air flow prevents formation of localised hot pockets and protects the electronic components from overheating. These filter fans are intended for indoor use. The plastic used for the hood is highly UV light resistant.

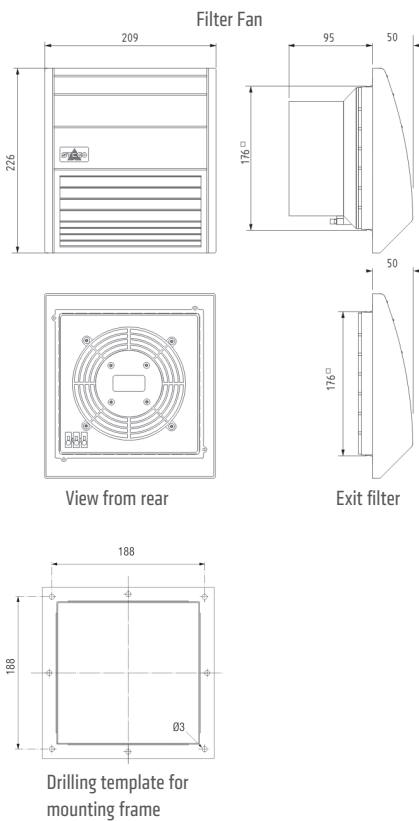

TECHNICAL DATA

Axial fan, ball bearing	service life 50,000h at +25°C (+77°F), 65% RH fan body aluminium, rotor metal
Connection	3-pole clamp for 2.5mm ² , clamping torque 0.8Nm max.
Casing (filter fan and exit filter)	plastic according to UL94 V-0, light grey
Hood (filter fan and exit filter)	plastic according to UL94 V-0, light grey; UV light resistant according to UL746C (f1)
Mounting frame	with double-sided industrial adhesive band for fixing to the outside of enclosure; certain operating circumstances can make the additional use of screws necessary (see drilling template); a template for the enclosure cut-out is included in the delivery of the filter fans
Filter mat	G4 acc. to DIN EN 779, filtering degree 94%
Filter material	synthetic fibre with progressive construction, temperature resistant to +100°C, self-extinguishing class F1, moisture resistant to 100% RH, reusable - cleaning by washing or vacuuming
Operating/Storage temperature	230VAC: -25 to +50°C (-13 to +122°F) 120VAC: -25 to +60°C (-13 to +140°F)
Operating/Storage humidity	max. 90% RH (non-condensing)
Protection class	I (earthed)
Approvals	UL File No. E234324, EAC, VDE only: 230V

FILTER FAN FF 018

Art. No.	Operating voltage	Air volume, free flow	Air volume with exit filter	Current consumption	Power consumption	Average noise level (DIN EN ISO 4871)	Depth in enclosure	Enclosure cut-out	Weight (approx.)	Protection type
01804.0-00	230VAC, 50Hz	200m ³ /h	125m ³ /h	320mA	45W	52dB (A)	95mm	176 x 176mm + 0.4	1.7kg	IP54/IP55 ¹
01804.0-01	120VAC, 60Hz	230m ³ /h	143m ³ /h	470mA	39W	52dB (A)	95mm	176 x 176mm + 0.4	1.7kg	IP54/IP55 ¹

EXIT FILTER EF 118

Art. No.	Depth in enclosure	Enclosure cut-out	Weight (approx.)	Filter mat	Protection type
11802.0-00	16mm	176 x 176mm + 0.4	0.6kg	G4 acc. to DIN EN 779, filtering degree 94%	IP54/IP55 ¹

FILTER MAT FM 086/FFM 086

Filter mat	168 x 168mm
G4 (1 packing unit = 3 pcs.)	Art. No. 08602.0-00
F5/M5 (1 packaging unit = 3 pcs.)	Art. No. 08605.0-00

¹ Using fine filter mats type F5/M5 increases the protection type to IP55, but reduces the air volume